

## Summit Gas Convection Oven

Item: \_\_\_\_\_  
 Quantity: \_\_\_\_\_  
 Project: \_\_\_\_\_  
 Approval: \_\_\_\_\_  
 Date: \_\_\_\_\_

### Models:

- SUMG-100
- SUMG-200



Model SUMG-100

Note: Ovens supplied with casters must be installed with an approved restraining device.

### Standard Features:

- Solid State control with electro-mechanical timer
- Direct spark ignition with 100% safety shutoff
- Two-speed fan control (high, low) with 0.6 HP fan motor
- Total of 53,000 BTU(15.53 kW) loading per oven cavity
- Natural or propane gas
- Stainless steel front, sides, top, and legs
- 60/40 dependent door design with double pane thermal window in left-hand door and interior lighting
- Porcelain enameled oven interior with coved corners
- Five (5) chrome plated oven racks on 13-position rack guides
- Double deck models available, 200 series models

- One year limited parts and labor warranty (USA and Canada only)
- Five year limited door warranty, excluding window (USA and Canada only)

### Optional Features:

- Windows in both doors
- 208 or 240 Volt convection oven motor
- Stainless steel solid doors
- Extra oven racks
- Swivel casters, (4) w/ front brakes
- Low profile casters, (4) w/ front brakes (double ovens only)
- Open base with rack guides and shelf (stainless steel)
- Direct connect vent
- Gas flex hose with quick disconnect & restraining device
- Back enclosure (stainless steel)
- Removable stainless steel drip pan

Summit Gas Convection Oven

### Specifications:

U.S. Range Summit Full-Size Standard Depth, gas convection oven. 53,000 BTU (15.53 kW) cavity, 0.6 HP fan motor with two-speed fan speed control. Direct spark ignition. Natural or propane gas. Solid State Control with 60-minute timer. Porcelain enameled oven interior with coved corners, five (5) oven racks and 13-position rack guides. All model interiors are 29" (736mm) W by 24" (610mm) H, depth is 24" (610mm) Stainless steel front, sides, top, and legs. 60/40 dependent door design with double pane thermal window in left-hand door and interior lighting. 200 Models are double deck units. Specify voltage if other than 115 volt, 60 Hz, 1 phase. UL, CUL Gas-Fired and NSF Listed.



Model	Int. Dimensions: In (mm)			Ext. Dimensions: In (mm)			Ship Wt	Ship Dim.
	W	H	D	W	H	D (w/motor)	Lbs/kg	Cubic Ft.
SUMG-100	29 (736)	24 (610)	24 (610)	38 (965)	57-1/2 (1461)	41-1/4 (1048)	515/230	64
SUMG-200	29(736)	24(610)	24(610)	38(965)	70-1/2 (1791)**	41-1/4 (1048)	1030/465	128

\*\* Height with or without standard casters. Height with low profile casters (double deck) is 68-1/2" (1740mm).

Models	Input Ratings, Natural & Propane			Operating Pressure *		Electrical Specifications	
	BTU/hr	kW Equiv.	Gas Inlet	Natural	Propane	120V/1Ph.	240V/1Ph.
Single Deck	53,000	15.53	(1) @ 3/4" NPT	4" WC (10 mbar)	10" WC (25 mbar)	(1)@9.8A	(1)@ 5.2A
Double Deck	106,000	31.06	(1)@1" NPT			(2)@9.8A	(2)@ 5.2A

\*Maximum Pressure 13.8" WC @ 70°F (21°C)

Many local codes exist and it is the responsibility of the owner and installer to comply with those codes. These appliances are intended for commercial use by professionally trained personnel.

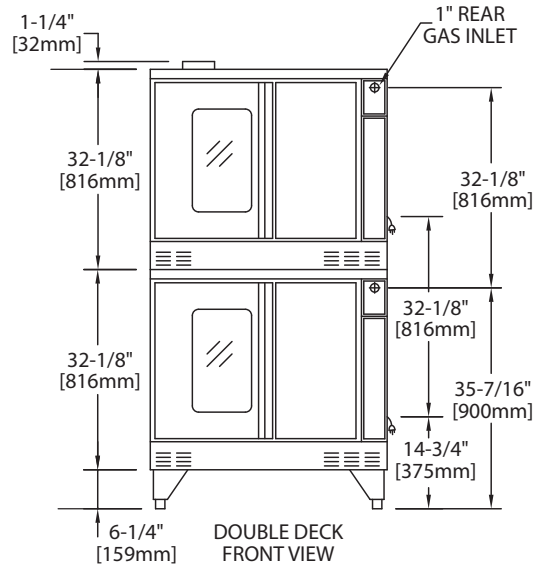
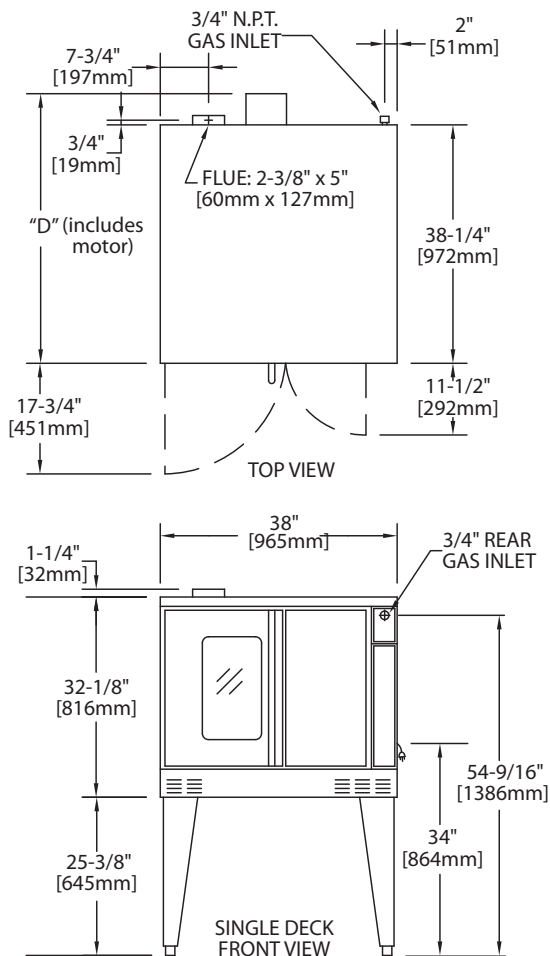

Installation Notes:			
Combustible & Non-Combustible Wall Clearances:			
Sides	*1" (25mm)	Back	3" (76mm)
*Note: Installations beside units with high heat sources it is recommended to leave 6" (152mm) on the right side of oven. Refer to the installation manual for more detail.			
Entry Clearances: In (mm)			
Crated	44" (1194mm)	Uncrated	32-1/2(826mm)

**Notes:**

- Standard electrical specifications include motor requirements.
- (120V units) 115V, 0.6 HP, 2-speed motor; 1140 and 1725 rpm, 60Hz.
- (240V units) 200-240V, 0.6 HP, 2-speed motor; 1140 and 1725 rpm, 60 Hz.
- A 6 ft. line cord is provided for each 120V deck with a (NEMA #5-15P) plug.
- U. S. Range recommends a separate 15 AMP circuit for each 120V unit.

Gas Input Ratings shown here are for installations up to 3,000 ft. (915m) above sea level. Specify altitudes over 3,000 ft.

Form# SUMG (03/11/21)