

# S686 Sentry Series Electric Restaurant Range

Project \_\_\_\_\_  
Item \_\_\_\_\_  
Quantity \_\_\_\_\_  
CSI Section 11400  
Approved \_\_\_\_\_  
Date \_\_\_\_\_

## Models

- S686
- SU686
- SS686



Model S686  
(shown with optional casters)

NOTE: Ranges supplied with casters must be installed with an approved restraining device.

## Standard Features

- Standard Features:
- Stainless Steel exterior
- 1 large, full-size oven with complete porcelain interior finish
- Removeable, 4-position, rack guides w/1 oven rack
- Electro-mechanical heavy duty oven thermostat, (150°F/66°C - 550°F/288°C)
- 6 tubular heating elements, infinite switch controlled
- Cool touch oven door handle
- 10" (254mm) high stainless steel backguard with slotted black enameled angled cap
- 6" (152 mm) high stainless steel legs - Adjustable
- 6 sealed, high performance elements with over heat protection and 6-heat switch in lieu of tubular elements, CE approved model SU686, or North American Model SS686
- 1 year limited warranty on parts & labor (USA & Canada only)

## Optional Features

- Convection oven base (add suffix - RC) with 3-position rack guide assembly and 3 oven racks
- 5/8" (16mm) thick thermostatically controlled griddle plate available in 12", add suffix 12G, 24" add suffix 24G and 36", add suffix 36G, standard on the right, left optional
- Solid Steel Hot top 1/2"(13mm) thick utilizing front and rear switch controls, available in 12", add suffix 1, and 24" add suffix 2, standard on the left, right optional (Note: Maximum (2)two hot top sections per range.)
- Additional Oven Rack
- Set of (4) Polyurethane (non-marking) swivel casters with front brakes.
- 17"(432mm) high stainless steel backguard with slotted black enameled angled cap
- Stainless steel two piece easy to assemble backguard and plate shelf
- Range mounted salamander broiler (Model SER-686). CE Marked range mounted salamander is SUER-686.
- Marine equipment - storm rails, oven door latch, drip tray stop and deck fasteners

## Specifications

Electric medium duty range with full size, all porcelain oven interior, contoured front stainless steel plate rail, 36" (914mm) wide, with 6 all purpose tubular heating elements. Stainless steel exterior, with stainless steel 10" (254 mm) high backguard with slotted black enameled angled cap. Available with optional sealed elements with "over heat protection" - reducing power if element is turned on w/o pan for 8 minutes, hot top(s) and griddle. Available with convection oven base.

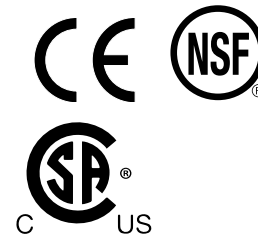

Note: Only models with prefix "SU" carry the CE Mark

S686 Sentry Series Electric Restaurant Range

# S686 Sentry Series Electric Restaurant Range

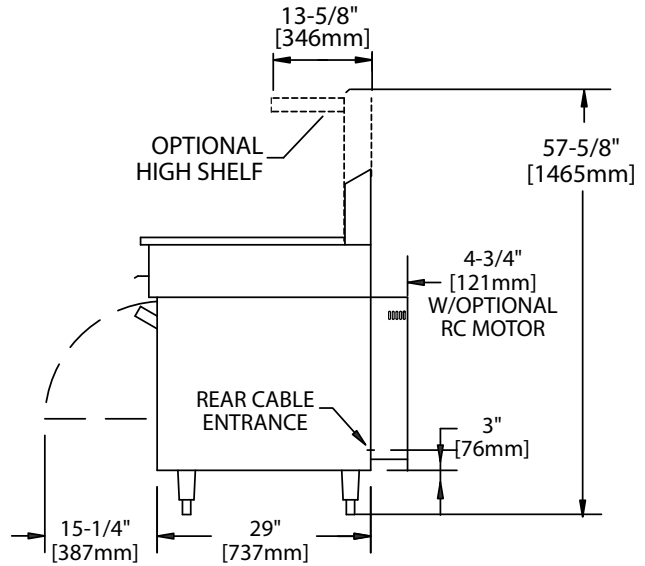
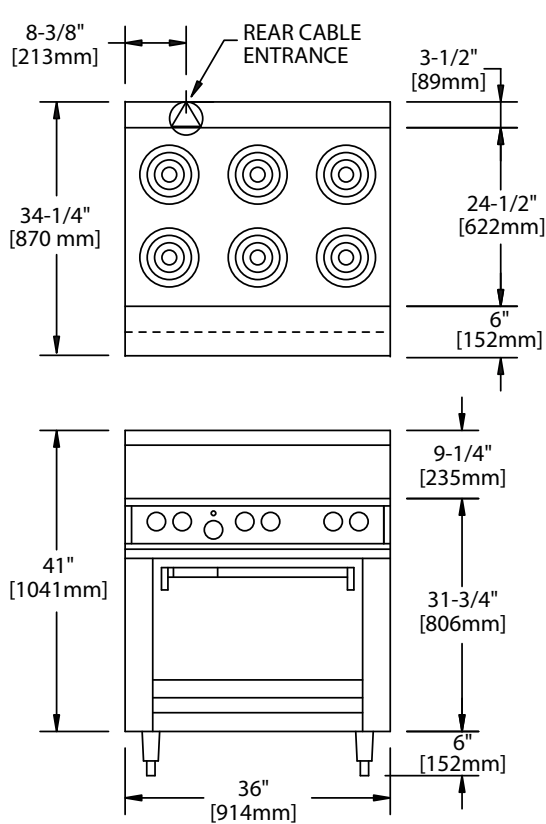
**Ratings:**

Tubular Elements: 6-1/2" (165mm): 1250 Watts  
8-1/2" (216mm): 2100 Watts

Sealed Elements: 7-1/2" (191mm): 2000 Watts  
9" (229mm): 2600 Watts

Hot Tops: (per 12"/305mm section):

Front and Rear sections each 1675 Watts, (3350 Watts total)

Griddle (per 12"/305mm section): 3350 Watts

Standard Oven: 4.85 kW

Convection Oven: 5.0 kW (+0.5kW fan motor; for 5.5kW total)

NOTE: For ranges with convection oven, (models with suffix "RC"), air circulation is required for proper operation of fan motors. These models must not be dais mounted or installed without legs.

Model	Total Kw Load	Nominal Amps			
		208V/1Ph	208V/3 Ph	240V/1Ph	240V/3 Ph
S686*	15	72	48	62	42
S686RC	16	75	51	64	44
SS/SU686**	19	90	59	78	52
SS/SU686RC	20	93	62	80	54
Salamander Broiler***	7	34	19	29	16

\*Tubular elements; \*\*Sealed -top elements, Model # S5686 in North America; \*\*\*Add when wired to range base (SER/SUER-680)

Exterior Dimensions			Oven Interior Dimensions		
Height	Width	Depth†	Height	Width	Depth
47" (1194mm)	36" (914mm)	34-1/4" (870mm)	13-1/2" (343mm)	26-1/4" (667mm)	22" (559mm)

† With front rail Note: Shipping Cubic Feet is 58.5

Installation Clearances:	Side	Back
Range w/o Salamander	3" (76mm)	2" (51mm)
Range w/Salamander	7" (178mm)	2" (51mm)
Hot Top	10" (254mm)	—

Entry Clearances		
Crated	Uncrated	Uncrated "RC" Model
45" (1143mm)	35" (889mm)	40" (1016mm)

NOTE: Many local codes exist, and it is the responsibility of the Owner and the Installer to comply with those codes.

Welbilt reserves the right to make changes to the design or specifications without prior notice.