



VACUUM PACKING MACHINE SE-416 120/50-60/1

Tabletop model. 16 m³/h. 420 mm.



P/N 1140637



FOOD PRESERVATION AND SOUS-VIDE
COMMERCIAL VACUUM PACKING MACHINES

SALES DESCRIPTION

420 mm sealing bar.
16 m³/h Busch vacuum pump.
Vacuum controlled by sensor.

- ✓ Powered by Busch.
- ✓ Vacuum controlled by sensor.
- ✓ Vacuum PLUS.
- ✓ Digital keyboard.
- ✓ Control panel equipped with display indicating the exact vacuum percentage.
- ✓ "Pause" button to marinate food.
- ✓ Safe liquid packing thanks to sensor control.
- ✓ Double seal.
- ✓ Cordless sealing bar.
- ✓ Bag-sealing programme.
- ✓ Pulse-controlled decompression.
- ✓ Vac-Norm ready with Automatic decompression.
- ✓ Stainless steel body and chamber. Deep-drawn chamber.
- ✓ Damped transparent lid.
- ✓ Dry-oil programme for drying the pump.
- ✓ Working hours counter for oil changes.
- ✓ Safety system with protection against vacuum failure.

INCLUDES

- | | |
|---|--------------------------|
| ✓ Sensor controls | ✓ BUSCH pump |
| ✓ Up to 10 seconds of extra vacuum pull | ✓ NSF approved |
| ✓ Soft air function | ✓ Clear methacrylate lid |
| ✓ Dry oil cycle | ✓ Filling plate |

OPTIONAL

- | | |
|---|---|
| <input type="checkbox"/> Vacuum packing bags | <input type="checkbox"/> Bag cutting kit |
| <input type="checkbox"/> External vacuum kit for Vac-Norm, containers and accessories | <input type="checkbox"/> Support for liquid packaging |
| | <input type="checkbox"/> Additional filling plates |

ACCESSORIES

- | | |
|---|---|
| <input type="checkbox"/> Bag cutting kits | <input type="checkbox"/> Smooth bags for vacuum packing |
| <input type="checkbox"/> Filling plates | <input type="checkbox"/> Trolley for vacuum packing machines |
| <input type="checkbox"/> Liquid insert plates | <input type="checkbox"/> Vacuum packing machines maintenance kits |
| <input type="checkbox"/> Vac-norm external vacuum kit | |
| <input type="checkbox"/> Vac-norm containers | |

SPECIFICATIONS

Pump capacity: (KD20) 16 m³/h
 Pump capacity (60 Hz): (KD20) 19 m³/h
 Bar length: 420 mm
 Total loading: 550 W
 Vacuum pressure (maximum): 2 mbar
 Electrical supply: 120 V / 60 Hz / 1~ (8 A)
 Plug: USA (NEMA 5-15P / 2P+G)

Internal dimensions

- ✓ Width: 430 mm
- ✓ Depth: 415 mm
- ✓ Height: 180 mm

External dimensions (W x D x H)

- ✓ Width: 484 mm
- ✓ Depth: 529 mm
- ✓ Height: 529 mm
- Net weight: 50.8 kg
- Background noise: 32 dB(A)
- Crated dimensions
600 x 600 x 610 mm
- Gross weight: 59.2 kg





VACUUM PACKING MACHINE SE-416 120/50-60/1

Tabletop model. 16 m³/h. 420 mm.



P/N 1140637

FOOD PRESERVATION AND SOUS-VIDE
COMMERCIAL VACUUM PACKING MACHINES

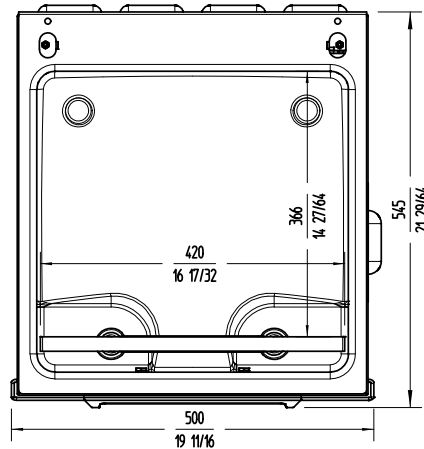
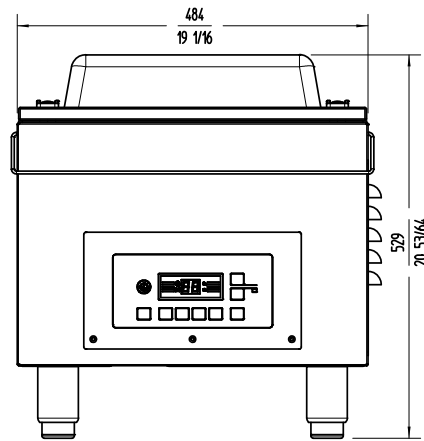
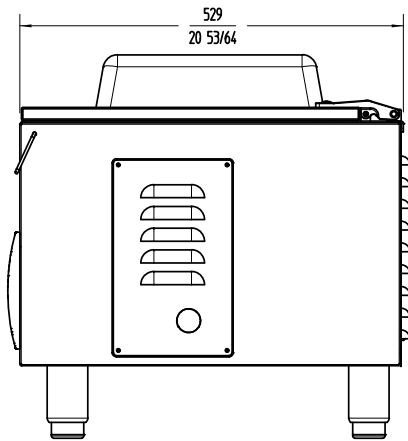

sammic | sammic.com
Food Service Equipment Manufacturer

Polígono Basarte, 1. phone +34 943 15 72 36
20720 Azkoitia, Spain sales@sammic.com



Project	Date
Item	Qty
Approved	

product sheet
updated 03/12/2025