

nexus

by MOYER DIEBEL

Undercounter High Temperature
Dishwashing Machine
with Built-in Booster Heater
Model N900



STANDARD FEATURES

ENERGY EFFICIENT

- ✓ Exclusive 30 amp breaker machine.
- ✓ Highly effective 5kW booster heater.

FUNCTIONALITY

- ✓ "NEW" Intuitive LCD Control Display clearly identifies temperature and cycle times.
- ✓ Automatic fill at start up.
- ✓ Exclusive pumped wash pushes pressurised water through the spray arms under pressure during the wash & rinse cycles.
- ✓ Double skin hinged door – an integral component made from industry leading design offers a robust quality to meet operational demand.
- ✓ AutoClean washes chamber at shutdown.
- ✓ Pumped Drain.
- ✓ 1 Year Limited Warranty (Parts & Labour).
- ✓ Complete with one peg rack.
- ✓ 100% designed and built.

SAFETY

- ✓ **nexus** safeguard - Monitors and assures 180°F/82°C is reached in final rinse temperature to meet NSF rated sanitization requirements.

SERVICEABILITY

- ✓ Visual Diagnostics guide the user through every step of the **nexus** N900 operating system including immediate service feedback.
- ✓ Designed with easy access to replacement parts for ease of service.
- ✓ Reduced downtime and cost of ownership.

INDUSTRY EXCLUSIVE - FILL AND DRAIN OPERATING PRINCIPLE

What does fill and drain mean?

The **nexus** system will automatically drain the water in the machine after every wash cycle and fill the **nexus** N900 with water prior to the rinse cycle which ensures your wares are sanitized using the cleanest water possible for industry leading wash results.

Why is this important?

nexus Fill & Drain Technology ensures clean water is used for every rinse cycle. The **nexus** N900 recycles this very rinse water for the next wash cycle which means your wares are clean and your machine is too. In addition, The **nexus** M900 undercounter maintains even water pressure during the industry exclusive pumped wash & rinse cycle. Great for heavy soil applications.

OPTIONS & ACCESSORIES

- | | |
|---|-------------|
| <input type="checkbox"/> 17RS – 17" Stand | P/N 0708757 |
| <input type="checkbox"/> Drain tempering kit | P/N 0714380 |
| <input type="checkbox"/> Flat bottom dishrack | P/N 101273 |



Made in Canada

nexus-Canada

2674 North Service Rd, Jordan Station, Ontario, Canada L0R 1S0 Tel: 800/263-5798 Fax: 905/562-5422

www.championindustries/1canada/nexus

Printed in CANADA

nexus Undercounter Specifications

nexus N900 Dimensions & Notes:

- Dimensions shown in inches and [millimeters]
- Allow additional 3" clearance from wall

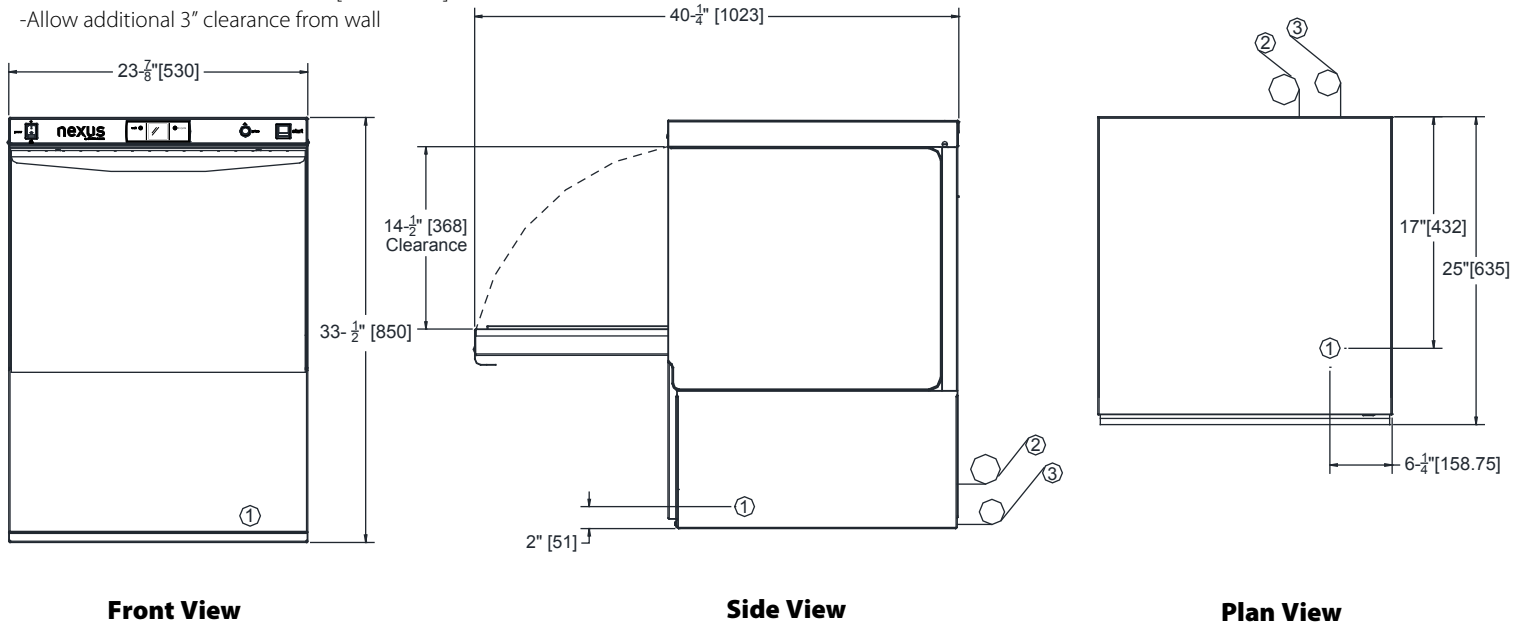

Utilities

- 1 Electrical**
208-230/60/1; 2 wire + ground; hard wiring required (see below)
- 2 Hot Water**
140°F/60°C Min
5 ft. long 1/2" I.D. flexible fill hose with 3/4" FNPT connection.
Flow pressure: 25-95 psi (172-655 kPa)
- 3 Drain Connection**
6 ft. long, 3/4" I.D. flexible hose.
Max. drain flow: 8 US gpm; 7 imp gpm
Drain height 3' -1/2"

5 kW Electric Booster

Elec. Specs	Rated Amps	Minimum Supply Circuit Ampacity	Maximum Overcurrent Protective Device
208/60/1	22	30	30
230/60/1	24	30	30

Shipping Details

	Uncrated	Crated
Height inches/mm	33-1/2" [850.9]	39-1/2" [1003]
Width inches/mm	24" [609]	25" [635]
Depth inches/mm	25" [635]	25-1/2" [647]
Ship Wt. lbs/kg	148/67	165/75

Electrical Supply Details

Electrical supply service must be a 2-wire plus ground for connection as shown

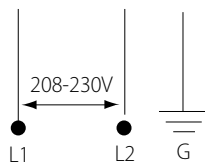

SPECIFICATIONS

Capacity	
Racks per hr. *	24
Motor Horsepower	
Wash	1
Water Consumption	
Gal. per hr. (max. use)	
US gal. (imp gal/liters)	27 (22.5/102)
Gal. per rack	
US gal. (imp gal/liters)	1.4 (1.16/5.3)
Temperatures °F/ °C	
Wash (minimum)	150/66
Rinse (minimum)	180/82
Heating	
Tank heat, electric (kW)	2
Electric booster (kW)	5
Time Cycle in Seconds	
Wash	85
Rinse	20
Dwell (Filling & Draining)	45
Total	150

* Excludes 30 second NSF load/unload time

Warning: Plumbing and electrical connections should be made by qualified personnel who will observe all the applicable plumbing, sanitary and safety codes.