



KT-0420 ICE KUBE MACHINE

KT-0420 Ice Kube Machine

Models

- KDT-0420A KYT-0420A KDT-0420W KYT-0420W



Koolaire KT-0420
Ice Kube Machine on K420 Bin

Koolaire by Manitowoc ice machines are designed, developed and tested by Manitowoc engineers to provide great ice production, energy efficiency and reliable service at an affordable price.

Performance/Features/Benefits

- Produces up to 457 lbs (207 kg) of ice per day**
- Performance certified by the Air Conditioning, Heating and Refrigeration Institute (AHRI)
- Energy Efficient models - visit EnergyStar.gov to view all Energy Star qualifying models
- Highly efficient electro-less nickel plated copper evaporators made in Manitowoc WI, USA
- Simple operation - only one control, three positions ON/OFF/CLEAN
- High-Tech exterior with smudge and fingerprint resistant stainless-like finish
- Better for the environment. Uses R410A refrigerant which lowers global warming potential by 48%
- Backed by the industry's best Manitowoc distribution network and service agents

Built for Easy Sanitation

- Easy access front facing evaporator
- One-touch remedial cleaning; requires minimal interaction; just add chemical and let the machine do the rest. No ice removal from bin needed. (Use Manitowoc De-scaler and Sanitizer only)
- For detail cleaning; all food zone components removable by hand (no tools required). Fast and easy
- All white plastic interior, no exposed tubes or wires, smooth rounded corners for fast easy wipe downs
- The food zone is sealed from above and on the back of the door panel with commercial grade rubber gaskets
- Alpha San anti-microbial agent molded in selected components
- **Available LuminIce II Virus and Bacteria Inhibitor**- Controls viruses, bacteria, mold and yeast within the food zone to keep the machine clean longer (order K00520 for 22" & 30" and K00521 for 48" machines)

Ice Machine Electric

115/60/1 standard
(also available in 208-230V)

Minimum circuit ampacity:

Air-cooled: 11.3 (115V) 6.2 (208-230V)
Water-cooled: 10.6 (115V) 5.8 (208-230V)

Maximum fuse size:

Air Cooled: 20 Amps (115V) 15 Amps (208-230V)
Water cooled: 20 Amps (115V) 15 Amps (208-230V)

Specifications

BTU Per Hour:
5,400 (average),
and 6,300 (peak)

Refrigerant:
R410A CFC - Free
Lowers global warming
by 48%

Operating Limits:

- Ambient Temperature Range: 40° to 110° F (4.4° to 43.3° C)
Water Temperature Range: 40° to 90° F (4.4° to 32.2° C)
- Water Pressure Ice Maker Water In:
Min. 20 psi (137.9 kPa)
Max. 80 psi (551.1 kPa)

**based on 70F air / 50F water

Ice Shape



HALF KUBE
3/8" x 1 1/8" x 7/8"
(.95 x 2.86 x 2.22 cm)

❄ = 100%



KUBE
7/8" x 7/8" x 7/8"
(2.22 x 2.22 x 2.22 cm)

❄ = 100%



KT0420 on K-420 Storage Bin

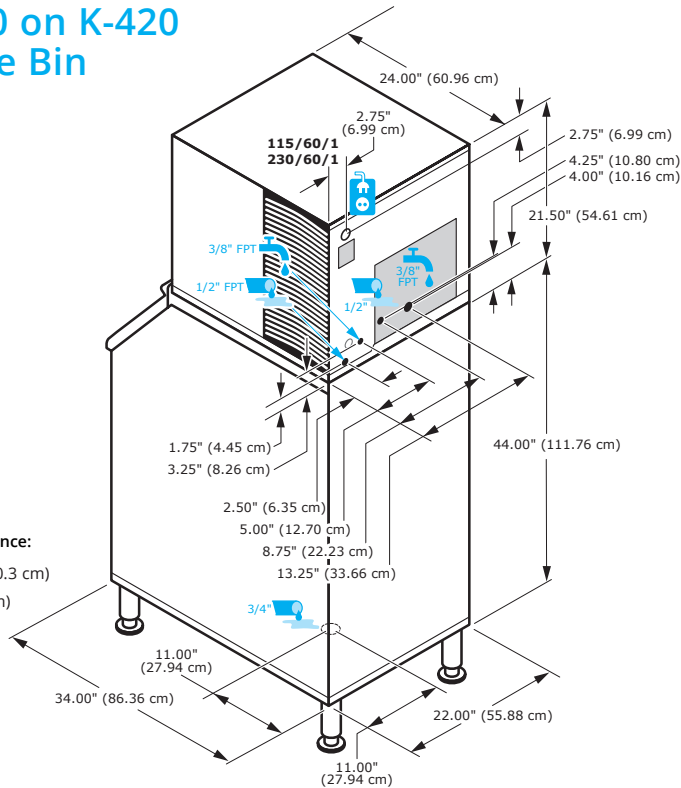

Required Clearance:

Top/Sides: 8" (20.3 cm)
Back: 5" (12.7 cm)

Water cooled condenser water usage/100 lbs. or 45.4 Kg. of ice: 160 gals. / 606L.

Space-Saving Design



KT0420
K-420

Height	71.50" 181.61 cm
Width	22.00" 55.88 cm
Depth	34.00" 86.30 cm
Bin Storage	383 lbs. 173 kgs.

Measurements with bin legs at 6.00" (15.24cm).
Adjustable bin legs 6.00" to 8.00" (15.24cm to 20.32cm). Bin capacity is based on 90% of the volume x 33 lbs/ft³ average density of ice.

Specifications

	Model	Ice Shape	Ice Production 24 Hours		Power Usage kWh/100 lbs. @90°Air/70°F	Potable Water Usage/100 lbs. of Ice
			70° / 50°F 21° / 10°C	90° / 70°F 32° / 21°C		
AIR COOLED	KDT-0420A	kube	440 lbs.	350 lbs.	5.8	19 Gal. 71.9 L
			199 kgs	159 kgs		
	KYT-0420A	half-kube	450 lbs.	360 lbs.	5.5 ★	19 Gal. 71.9 L
			204 kgs	163 kgs		
WATER COOLED	KDT-0420W	kube	457 lbs.	375 lbs.	4.6	19 Gal. 71.9 L
			207 kgs	170 kgs		
	KYT-0420W	half-kube	435 lbs.	390 lbs.	4.6	19 Gal. 71.9 L
			197 kgs.	177 kgs		

Order ice machine and bin separately
★ indicates Energy Star 3.0 certified

Shipping Weight:

Air-cooled: 137 lbs (62kg)
Water-cooled: 138 lbs (63 kg)



Accessories

Dispenser Bin Thermostat Kit

Reduces condensation when used with dispensers.



Top Air Discharge Kit

Convert air flow to rear in-take / top exhaust.

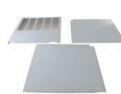

Arctic Pure Plus® Water Filters

reduce sediments and chlorine contaminants down to .5 microns. Use with a Pre-filter is recommended.



Luminice II Virus and Bacteria Inhibitor

controls viruses and bacteria inside the ice machine



Manitowoc Ice reserves the right to make changes to the design or specifications without prior notice.