

**BIZERBA****Food Service**

Bizerba GSP V series slicers certified to the stringent NSF/ANSI Standard 8-2017

Operator &amp; Food Safety are our top-priorities ...

... GSP V 2-150 GVRB Restaurant series,  
manual safety slicer ...**GSP V 2-150-GVRB with side lift-arm and 150mm wide thumb guard**

- Energy Efficiency: 1/2 H.P. motor, 319 r.p.m.
- High Yield: Operating time, designed for restaurants, 8-hour intermittent operation
- High Yield: Wide product carriage for increased capacity
- High Yield: Heavy-duty, 2 lb. blade knife cover
- High Yield: Debris deflector, permanently mounted, included
- High Yield: Precision machined pencil-point-grooves on gauge plate, blade cover and carriage to reduce friction, better looking product
- Safety Interlock: No-volt release
- Safety Interlock: Carriage-system and Gauge-plate lock during the cleaning and sanitizing process
- Operator Safety: 5.8"W (150mm) x 11.5"H x 2.0"D thumb guard wall for maximum protection
- Operator Safety: 360° blade enclosure for quick easy cleaning and sanitizing, no top-gaps in blade-ring guard
- Operator Safety: Zero blade exposure during the cleaning process
- Operator Safety: Front mounted controls
- Operator Safety: Rear mounted lift arm with largest and easiest to use remnant holder with 304 holding points, removable for cleaning, dish-machine safe
- Operator Safety: Low profile carriage for easy loading of heavy product
- Operator Safety: Side lift arm, stable two-wheel lift system for safe, easy cleaning under slicer, included
- Operator Safety: Recommended 31.25" - above floor height
- Food Safety: Remote sharpener is dishwasher safe for improved safety and hygiene; spring-loaded dial insures correct and consistent sharpening
- Food Safety: One piece anodized aluminum construction
- Food Safety: Non-removable carriage system for faster cleaning and sanitizing
- Food Safety: Double-sided seal between blade knife and housing, no gap for food to collect, better hygiene
- Food Safety: UL157 dairy grade seals and gaskets used to seal against water and food debris, no silicone used under seals, better hygiene
- Food Safety: Liquid and debris diversion from all control surfaces
- Food Safety: Remote blade sharpener does not collect food debris during operation and is dishwasher safe for improved safety and hygiene
- Food Safety: One piece carriage with seamless thumb guard for highest hygiene standards, no slotted-screw heads on thumb guard
- One Year Warranty: On-site, labor and parts

Side Lift arm,  
included**13" Grooved Vacuum Release  
Blade is the best in the industry**

The unique design of our blade produces clean and consistent slices. The hardness results in a long lasting sharp edge. The life of the blade is dramatically longer than the competition. Our standard blade is the hardest, thinnest, largest, straightest blade in the industry.

- 13" diameter, Grooved Vacuum Release Blade, chromium coated hard alloy
- 60-62 Rockwell hardness at the edge



Model #: GSP V 2-150 Restaurant Series | Stock #: 913005002

C.S.I. Division 11 | Section 4000

Project Name: \_\_\_\_\_ AIA # \_\_\_\_\_

Location: \_\_\_\_\_ SIS # \_\_\_\_\_

Item Number: \_\_\_\_\_

Quantity: \_\_\_\_\_

# BIZERBA

## Food Service

### 1-phase AC current

- 110 V, specialized data available on request
- 60 Hz
- Frequency of nominal current 1.79 A
- Power consumption 0.36 kW
- 1/2 hp

### Blade diameter

- 13" (330 mm)

### Blade speed

- 319 r.p.m.

### Max. produce size

- Round: 8.98" (228 mm)
- Height: 6.3" (160 mm)
- Width: 11.42" (290 mm)

### Slice thickness

- 0-0.94" (0-24 mm), infinitely variable

### Thumb-guard rear wall

- 5.8"W x 11.5"H x 2"D (150 x 235 x 67 mm)

### Gravity-feed slicing carriage

- 40° inclined gravity feed

### H - Carriage inclination

- Carriage inclined 25° towards operator
- Carriage height positioned towards center of blade

### Noise control drive system

- 58.0 dB decibel level

### Installation area

- Above Counter Height (ACH): The ACH of 3.5" includes 1.0" legs and rubber feet. Unit ships with optional 2" leg extension kit and raises the ACH to 5.5".
- Lift-arm installed for cleaning under slicer
- (L x W) 20.94" x 18.82" (532 x 478 mm)

### External dimensions

- (L x W x H) 28.45" x 22.44" x 26" (725 x 570 x 660 mm)

### Operating area

- (L x W) 29.9" x 33.98" (759 x 863 mm)

### Food Safety - Ingress Protection type

- IP Solids level 3 | Liquids level 3

### Weight of machine

- 95 lbs, 43 kg

### Shipping Details & Dimensions

- Total Shipping Dimensions (L x W x H): 32.5" x 27.8" x 32" (826 x 706 x 813 mm)
- Total Shipping Weight: 124 lbs, 56.3 kg
- Cubic: Ft. 16.73, 0.47 m
- Density: 7.41 lb/cubic ft, 118.95 kg/cubic m

### Additional equipment

- SlicerGard™ Service Protection Plans, from 12 to 60 month coverage
- 13" (330 mm) Grooved Vacuum Release Cheese Blade



GSP V 2-150-GVRB

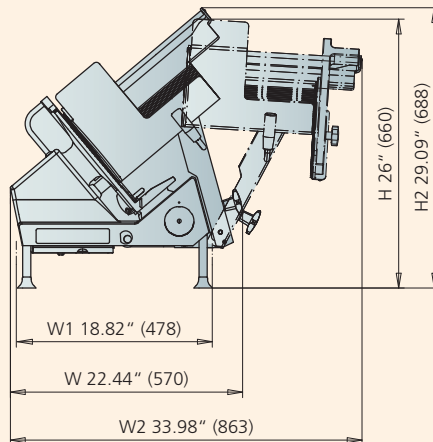
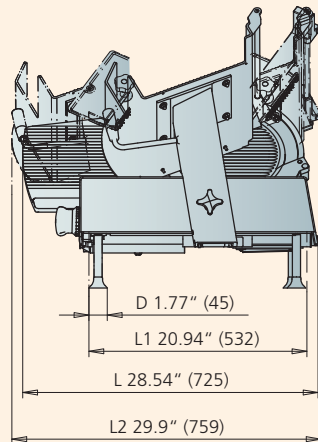

### Warranty

The GSP V Restaurant Series Slicer carries a one-year, on-site parts and labor warranty against any flaws in materials and workmanship. This period begins with the date of purchase and, provided the unit is used properly in accordance with our instructions, is in full effect for one year from that date. Any work to be performed under this warranty must be performed between the hours of 8:00 a.m. and 4:30 p.m. local time, Monday to Friday. Bizerba will not pay over-time charges for work performed other than during normal business hours. Accessories have a 30-day replacement or repair warranty for the period beginning on the date of purchase. Damages incurred in transit or from installation error, accident, alteration or misuse are not covered. Transit damages should be reported to the carrier immediately. Bizerba shall not be liable for any consequential, compensatory, incidental, or special damages. All warranty work must be performed by a factory authorized Bizerba Representative.

### Members of the Bizerba Group

Bizerba GmbH & Co. KG  
Wilhelm-Kraut-Straße 65  
72336 Balingen  
Germany  
Tel. +49 7433 12-0  
Fax +49 7433 12-2696  
marketing@bizerba.de  
www.bizerba.com

Bizerba USA Inc.  
1804 Fashion Court  
Joppa, MD 21085  
USA  
Tel. Office +1 732 565-6000  
Tel. Service +1 732 565-6001  
Fax +1 732 819-0429  
us.foodservice@bizerba.com  
www.bizerba.com

Bizerba Canada Inc.  
6411 Edwards Blvd.  
Mississauga, Ontario L5T2PT  
Canada  
Tel. +1 888 240-3722  
French Tel. +1 877 699-2199  
Fax +1 905 816-0497  
ca.info@bizerba.com  
www.bizerba.ca

Bizerba de México, S.A. de  
C.V. Av. Rio Mixcoac No. 157  
Colonia Florida  
01030 México, D.F.  
México  
Tel. +52 55 5663-1397  
Fax +52 55 5663-1296  
contacto@bizerba.com.mx  
www.bizerba.com.mx