

efi sales Ltd.

Equipment for the Foodservice Industry

value + quality + service

X-LINE 60" Undercounter Solid Door Freezer

Model No:

FUDR2-60VCX



FUDR2-60VCX

Features

Features:

- Stainless steel interior and exterior, aluminum back
- Rounded corner design inside the cabinet for easy cleaning
- Self-closing swing door w/90°stay open feature
- Heavy duty recessed pull handles
- Adjustable/removable plastic coated wire shelves
- R290 refrigeration system holds -8°F to 0°F (-22°C to -18°C)
- Electronic control system makes it easy to adjust temperature set point and defrost frequency

- Casters with brakes for easy movement
- Easy to access condenser coil for cleaning and service

Warranty:

- Two year parts and labour; Five years on compressor. For full warranty details visit <https://www.efifoodequip.com/warranty-info.php>



FUDR2-60VCX Specifications

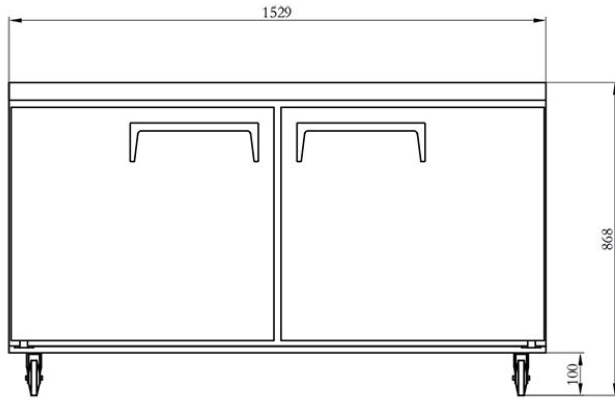

ELEVATION

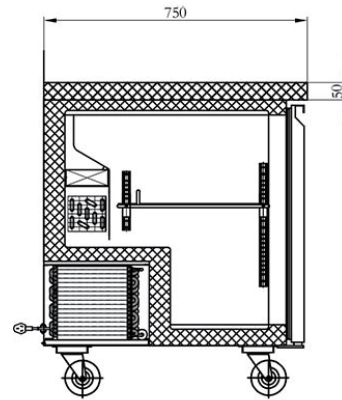

SECTION VIEW

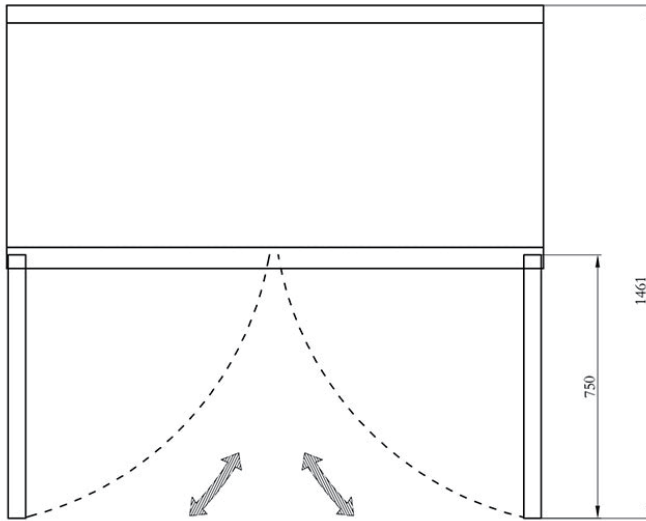

PLAN

Model	Refrigerant	Doors	Shelves	Dimension (mm) (inch)			HP	Voltage	Amps	Capacity (L) (Cu Ft.)	Net Weight (KG) (LBS)	Temperature Range
				W	D	H						
FUDR2-60VCX	R290	2	2	1529	750	868	2/3	115/60	5	428	104	-8 ~ -1°F
				60.2	29.5	34.1				15	229	-22 ~ -18°C

Specifications subject to change without notice.