



DF Revolution

Rotary Type Fully Automatic Glasswashing Machine



Project _____
 Item No. _____
 Quantity _____

MODEL DF GLASSWASHER

ALL NEW STANDARD FEATURES

- **Integrated Tank & Wash Chamber** – Operator-centric design for easy access during daily use.
- **Auto Fill, Clean, & Drain** – Requires no operator action.
- **AI Water Quality Monitoring** - Refreshes wash water as needed during operation without interruption.
- **Revolutionary EZ-Clip Wash & Rinse Arms** – Design for easy removal and cleaning.
- **38% Less Water Consumption** – Industry-leading water savings.
- **Compact 24" Wide Design**
- **Smart Controls** – On board machine diagnostics.
- **2" LCD Screen** – For intuitive operation.
- **Multi Speed System (low/med/high)** – Direct drive conveyor motor with anti-jam, and adjustable speed control to produce premium results for all soil conditions for all glassware.
- **Touchless Conveyor Shut-Off** – Advanced sensor technology reduces risk of damage to delicate glassware.
- **Self-Flushing Rinse Chamber** – Reduces cleaning requirements during operation due to channeling water to reduce soil build up.
- **Solid State Sensors** – No mechanical switches and no adjustments required.

BEST-IN-CLASS CORE FEATURES

- **12" Glass Clearance** – Fits taller stemware.
- **Double-walled Construction** –For quiet operation.
- **Cool Final Rinse** – Glasses are ready for immediate use.
- **Polypropylene Conveyor** –Prevents chipping of delicate glassware.
- **Smart LED Lights** – Customizable lighting for operator conditions and integrated notifications.

OPTIONAL PREMIUM FEATURES

- Integrated Chemical Monitoring** – Optimal results for washing and sanitizing (factory installed only).

Specifier Statement

Specified unit will be Moyer Diebel model DF Revolution Rotary Type, fully automatic glasswasher. Unit shall include integrated controller complete with LCD display providing system status and Operator feedback, automatic fill, clean, self flushing rinse chamber, draining features with a multi speed conveyor for adjustable wash settings, touchless conveyor shut-off, automated system diagnostics and AI water quality monitoring. Additional standard features include 24" wide cabinet, electric tank heater, removable and cleanable upper and lower wash/rinse arms, polypropylene conveyor, splash curtain, double wall construction detergent, rinse and sanitizing pumps with capacity to store three 1-gallon containers.

ACCESSORIES

- | | |
|--|-------------|
| <input type="checkbox"/> Drain tray and waste collector (DFWC) | P/N 0715145 |
| <input type="checkbox"/> Quick disconnect package (incl. casters) | P/N 0707258 |
| <input type="checkbox"/> Casters; set of four – 2 locking, 2 regular | P/N 0701962 |
| <input type="checkbox"/> Bar Mat (Size 23 5/8" x 17") | P/N 0715155 |

Patents Pending

Dimensions shown in inches and [millimeters]

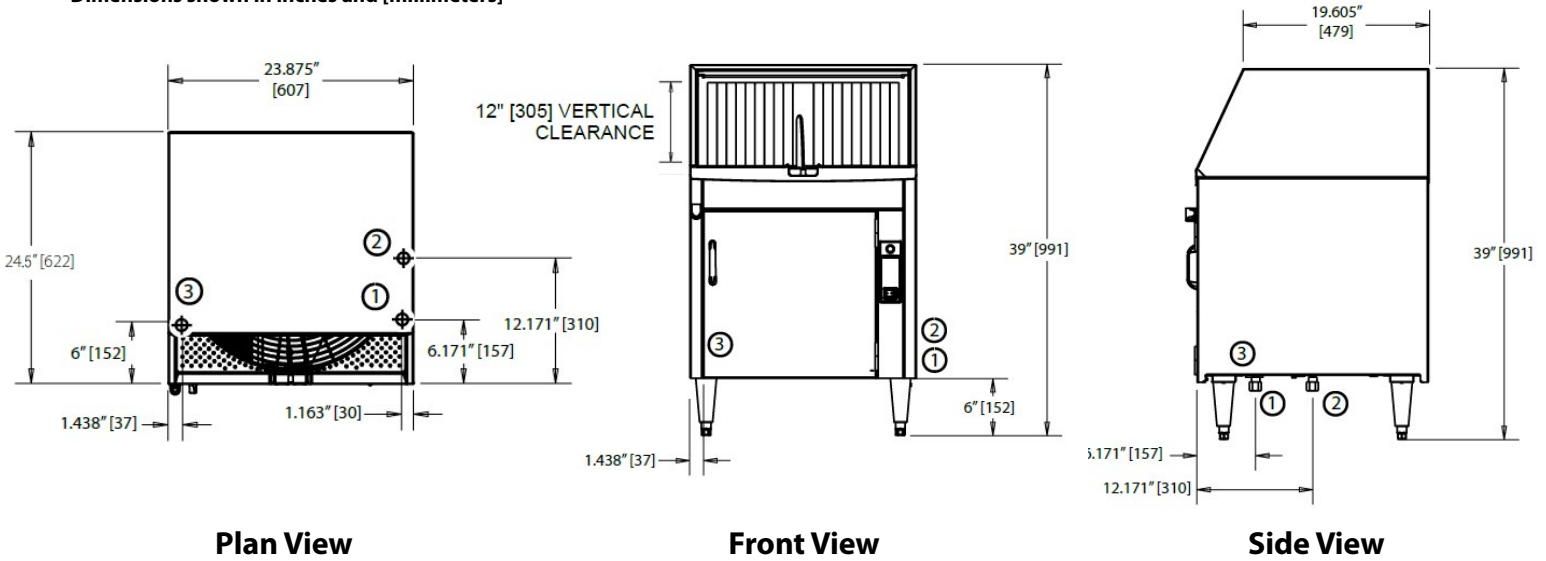

UTILITIES	
	Electrical 230/60/1, 15amp breaker
1	Hot water connection 1/2" [13] IPS. Flow pressure 25-95 psi [172.5-656 kPa]
2	Cold water connection 1/2" [13] IPS. Flow pressure 25-95 psi [172.5-656 kPa]
3	Drain connection (PEAK FLOW RATE 6.5 gpm) 1-1/2" [38] tailpiece. Connect to drain size according to local plumbing code.

	Uncrated	Crated
Height	39" [991]	46-1/2" [1181]
Width	23-7/8" [607]	27" [685]
Depth	24-1/2" [622]	27-1/2" [698]
Ship Wt. lbs/kg	156/71	176/80
* Adjustable foot height - 1 1/4" [45]		

Moyer Diebel – Canada
 2674 N. Service Rd, Jordan Station, Ontario, Canada L0R 1S0
 (800) 263-5798 • Fax: (905) 562-5422
 mdlcanada.com • sales@moyerdiebellimited.com

Moyer Diebel – USA
 3765 Champion Blvd., Winston-Salem NC 27105
 (800) 228-8350 • Fax: (336) 661-1979
 moyerdiebel.com • info@moyerdiebel.com

NOTE: DF Models supplied with 6 ft. [1829] plug in cord. (NEMA 6-15P)

Warning: Plumbing and electrical connections must be made by qualified personnel who will observe all the applicable plumbing, sanitary and safety codes.

TECHNICAL SPECIFICATIONS	
Capacity (hr.) 2-1/2" [64] glasses	1200
Water Consumption Cold water (approx.)	6.06 l/m 1.6 US gpm
Hot water (initial fill)	11.35 liters 3 US gallons
Max use (approx.)	45.42 liters/h 12 US gph
Temperatures Inlet water (hot)	61-69°C 140-160°F
Inlet water (cold)	24°C 75°F
Heating Tank heat, electric	3 kW
Conveyor Movement	Clockwise

* Due to an ongoing value analysis program at Moyer Diebel, specifications in this catalog are subject to change without notice