



Equipment for the Foodservice Industry

value + quality + service

Work Top Refrigeration

CWDR2-60VC



CWDR2-60VC

Features

Features:

- Exterior & interior stainless steel construction
- Environmentally friendly R290 refrigerant
- Heavy duty Embraco compressor
- Self-closing and stay open door
- Efficient refrigeration system holds 33°F to 45°F (0.5°C to 8°C)
- Recessed door handle
- Removable gasket that is easy to clean and replace
- Casters for easy movement
- Pre-installed shelves

Warranty:

- Two year parts and labour; Five years on compressor. *For full warranty details visit <https://www.efifoodequip.com/warranty-info.php>*



CWDR2-60VC Specifications

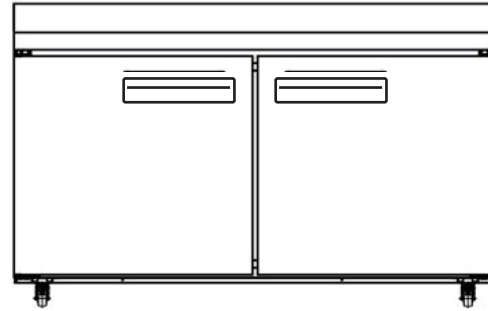
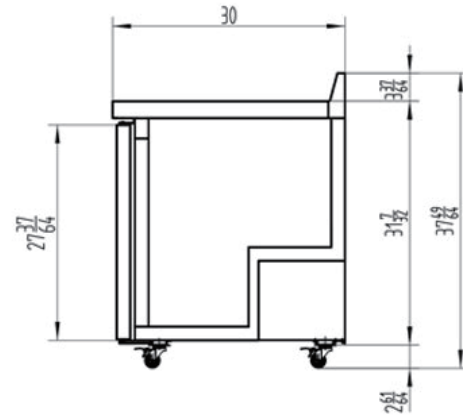
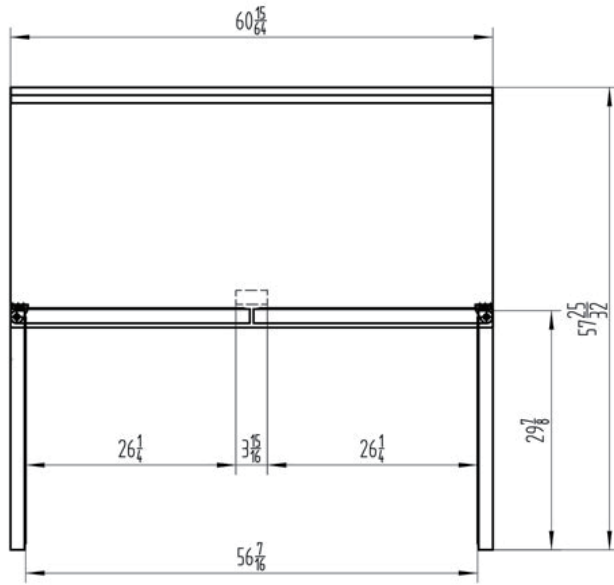

Model	Refrigerant	Doors	Shelves	Dimension (mm) (inch)			HP	Voltage	Amps	Capacity (L) (Cu Ft.)	Net Weight (KG) (LBS)	Temperature Range
				L	D	H						
CWDR2-60VC	R290	2	2	1530	762	959	1/5	115/60	2.8	487	101	1 ~ 8°C
				60.2	30.0	37.8						17.2

Equipped with one NEMA 5-15P plug 

Shipping Information

Crate Dimensions (mm) (inch)			Net Weight (KG) (LBS)	Gross Weight (KG) (LBS)
L	D	H		
1585	831	1077	105	126
62.4	32.7	42.4	218	277

Specifications subject to change without notice.