



Equipment for the Foodservice Industry

value + quality + service

Salad/Sandwich Prep Tables

CSDR2-60VC



CSDR2-60VC

Features

Features:

- Front breathing, side mount compressor
- Exterior & interior stainless steel construction
- Environmentally friendly R290 refrigerant
- Heavy duty Embraco compressor
- Self-closing and stay open door
- Efficient refrigeration system
- Recessed door handle
- Standard safety door lock
- Magnetic door gaskets
- Casters for easy movement
- Pre-installed shelves

Warranty:

- Two year parts and labour; Five years on compressor. For full warranty details visit <https://www.efifoodequip.com/warranty-info.php>



CSDR2-60VC

Specifications

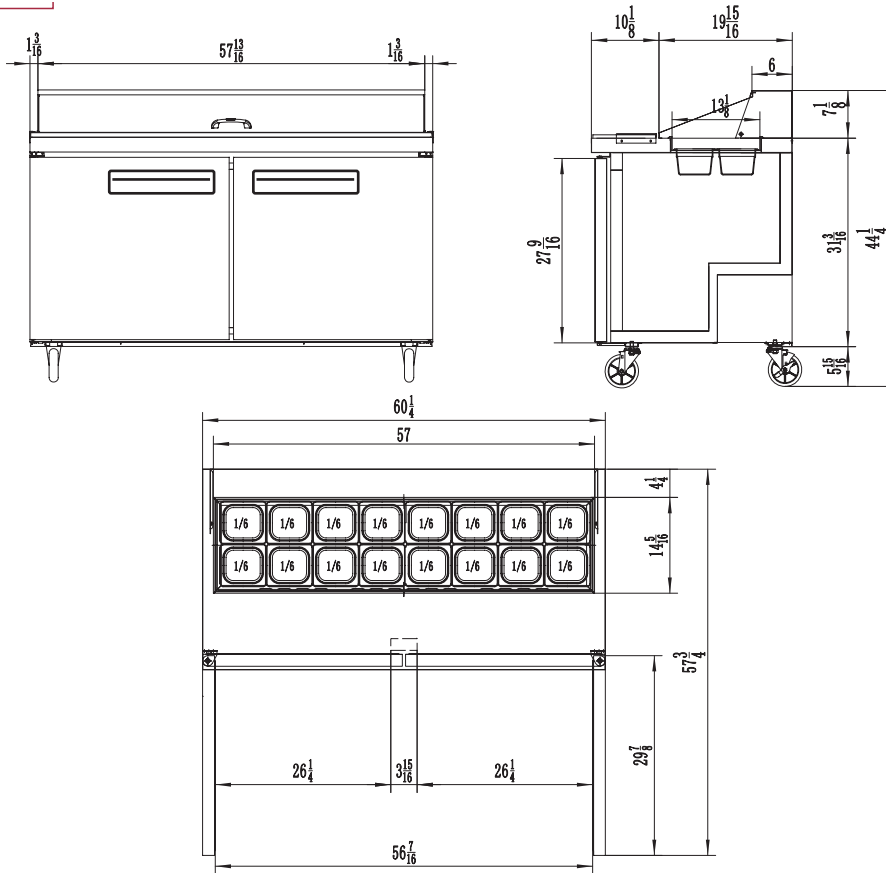

Model	Refrigerant	Doors	Shelves	Dimension (mm) (inch)			HP	Voltage	Amps	Capacity (L) (Cu Ft.)	Net Weight (KG) (LBS)	Temperature Range
				L	D	H						
CSDR2-60VC	R290	2	2	1530	762	1109	1/5	115/60	2.8	487	123	1 ~ 8°C
				60.2	30.0	43.7						

Equipped with one NEMA 5-15P plug 

Shipping Information

Crate Dimensions (mm) (inch)			Net Weight (KG) (LBS)	Gross Weight (KG) (LBS)
L	D	H		
1585	831	1186	123	145
62.4	32.7	46.7	271	320

Specifications subject to change without notice.