



Equipment for the Foodservice Industry

value + quality + service

Mega-Top Prep Table

CMDR2-48VC



CMDR2-48VC

Features

Features:

- Front breathing, side mount compressor
- Exterior & interior stainless steel construction
- Environmentally friendly R290 refrigerant
- Heavy duty Embraco compressor
- Self-closing and stay open door
- Efficient refrigeration system
- Recessed door handle
- Standard safety door lock
- Magnetic door gaskets
- Casters for easy movement
- Pre-installed shelves

Warranty:

- Two year parts and labour; Five years on compressor
- Specifications subject to change without notice



CMDR2-48VC Specifications

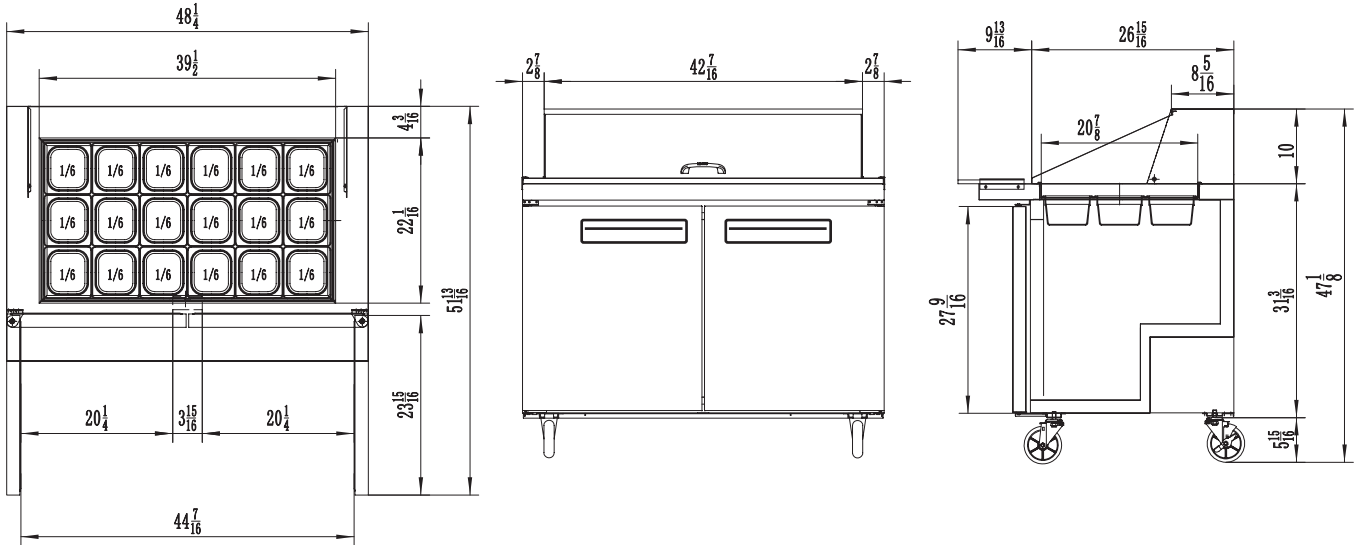

| Model | Refrigrant | Doors | Shelves | Dimension (mm) (inch) | | | HP | Voltage | Amps | Capacity (L) (Cu Ft.) | Net Weight (KG) (LBS) | Temperature Range |
|------------|------------|-------|---------|-----------------------------|------|------|-----|---------|------|-----------------------------|--------------------------------|----------------------|
| | | | | L | D | H | | | | | | |
| CMDR2-48VC | R290 | 2 | 2 | 1225 | 863 | 1183 | 1/6 | 115/60 | 2.3 | 416 | 110 | 1 ~ 8°C |
| | | | | 48.2 | 34.0 | 46.6 | | | | | | |

Equipped with one NEMA 5-15P plug 

Shipping Information

| Crate Dimensions (mm) (inch) | | | Net Weight (KG) (LBS) | Gross Weight (KG) (LBS) |
|------------------------------------|------|------|-----------------------------|-------------------------------|
| L | D | H | | |
| 1280 | 932 | 1247 | 110 | 133 |
| 50.4 | 36.7 | 49.1 | 243 | 293 |

Specifications subject to change without notice.