



Equipment for the Foodservice Industry

value + quality + service

Mega-Top Prep Table

CMDR1-27VC-L



CMDR1-27VC-L Features

Features:

- Front breathing, side mount compressor
- Exterior & interior stainless steel construction
- Environmentally friendly R290 refrigerant
- Heavy duty Embraco compressor
- Self-closing and stay open door
- Efficient refrigeration system
- Recessed door handle
- Standard safety door lock
- Magnetic door gaskets
- Casters for easy movement
- Pre-installed shelves

Warranty:

- Two year parts and labour; Five years on compressor. For full warranty details visit <https://www.efifoodequip.com/warranty-info.php>



CMDR1-27VC-L Specifications

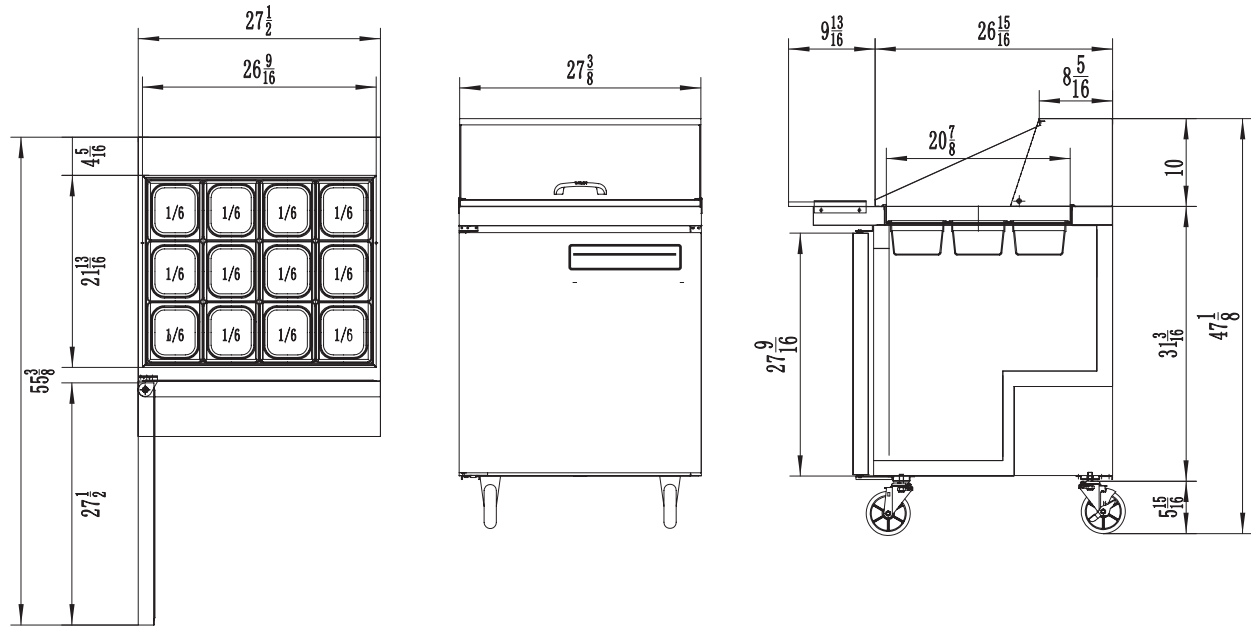

Model	Refrigrant	Doors	Shelves	Dimension (mm) (inch)			HP	Voltage	Amps	Capacity (L) (Cu Ft.)	Net Weight (KG) (LBS)	Temperature Range
				L	D	H						
CMDR1-27VC-L	R290	1	1	698	863	1183	1/6	115/60	2.3	224	77	1 ~ 8°C
				27.5	34.0	46.6				7.9	169	33 ~ 45°F

Equipped with one NEMA 5-15P plug 

Shipping Information

Crate Dimensions (mm) (inch)			Net Weight (KG) (LBS)	Gross Weight (KG) (LBS)
L	D	H		
752	932	1247	77	96
29.6	36.7	49.1	170	212

Specifications subject to change without notice.