



Equipment for the Foodservice Industry

value + quality + service

Chef Base Drawered Refrigeration

CCB-36



CCB-36

Features

Features:

- Stainless steel interior and exterior, with matching aluminum finished back
- Round corner design inside of cabinet
- Cabinet top is one piece, heavy duty reinforced stainless steel
- Electronic control system for adjustable temperature and defrost frequency
- Drip resistant "V" edge protects against spills
- Easily accessible condenser coil for cleaning
- Standard heavy duty casters
- Refrigeration system holds 33°F to 41°F (-0.5°C to 5°C) for optimum food preservation

Warranty:

- Two year parts and labour; Five years on compressor. *For full warranty details visit <https://www.efifoodequip.com/warranty-info.php>*



CCB-36

Specifications

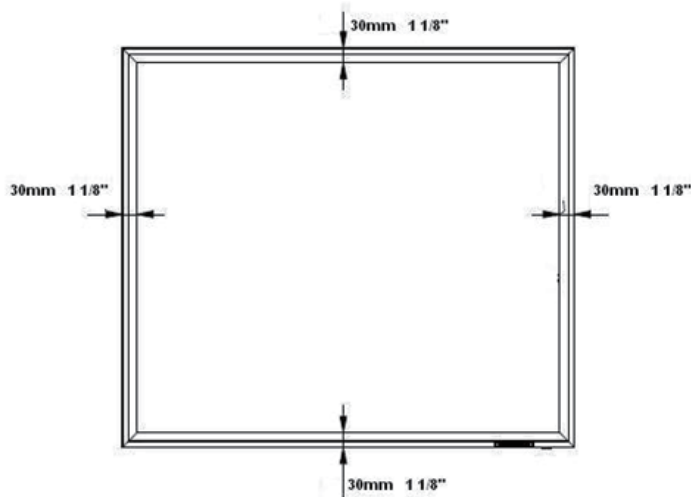
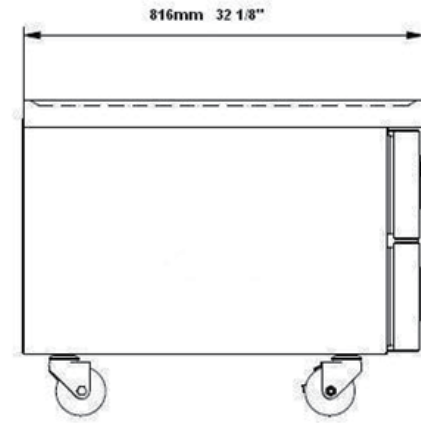
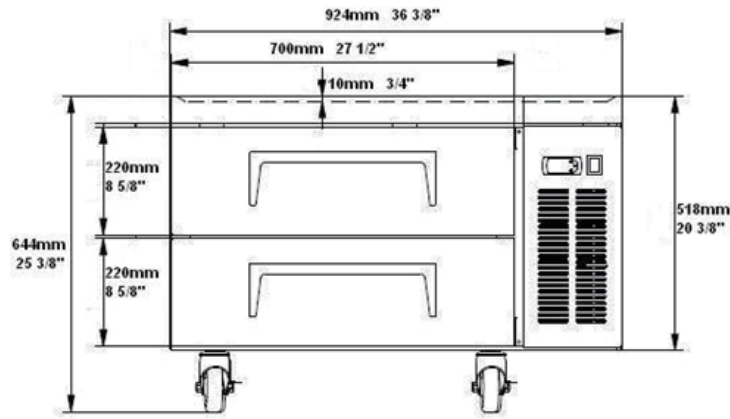

Model	Drawers	Dimension (mm) (inch)			HP	Voltage	Amps	Capacity	Net Weight (KG) (LBS)	Temperature Range	NEMA Config.
		L	D	H							
CCB-36	2	924.6	815.3	645.2	1/6	115/60/1	2.52	2 full size pans	126.6	0.5 ~ 5°C	5-15P ⓘ
		36.4	32.1	25.4					279	33 ~ 41°F	

Specifications subject to change without notice.