



Equipment for the Foodservice Industry

value + quality + service

## 24" Back Bar Direct Draw Dispensing Cooler - Black

Model No:

**CBBDD1-24CC**



### CBBDD1-24CC

### Features

Features:

- Exterior covered in an easy to maintain black vinyl
- Counter tops and interiors are made with Type 304 stainless steel
- Recessed handles
- Swing door equipped with locks for security
- Self-closing doors equipped to stay open when past 90 degrees
- Adjustable/removable plastic coated shelves
- Refrigeration system holds 33°F to 41°F (-0.5°C to 5°C) for optimum food preservation
- Removable door gasket for easy cleaning and service

- R290 refrigerant
- Foamed-in polyurethane cell insulation
- Chrome plated taps (1 tower with 2 taps)
- Couplings for attaching the kegs are connected
- Tubing and regulator for connecting the beer gas is not included

Warranty:

- Two year parts and labour; Five years on compressor. *For full warranty details visit <https://www.efifoodequip.com/warranty-info.php>*



**CBBDD1-24CC Specifications**

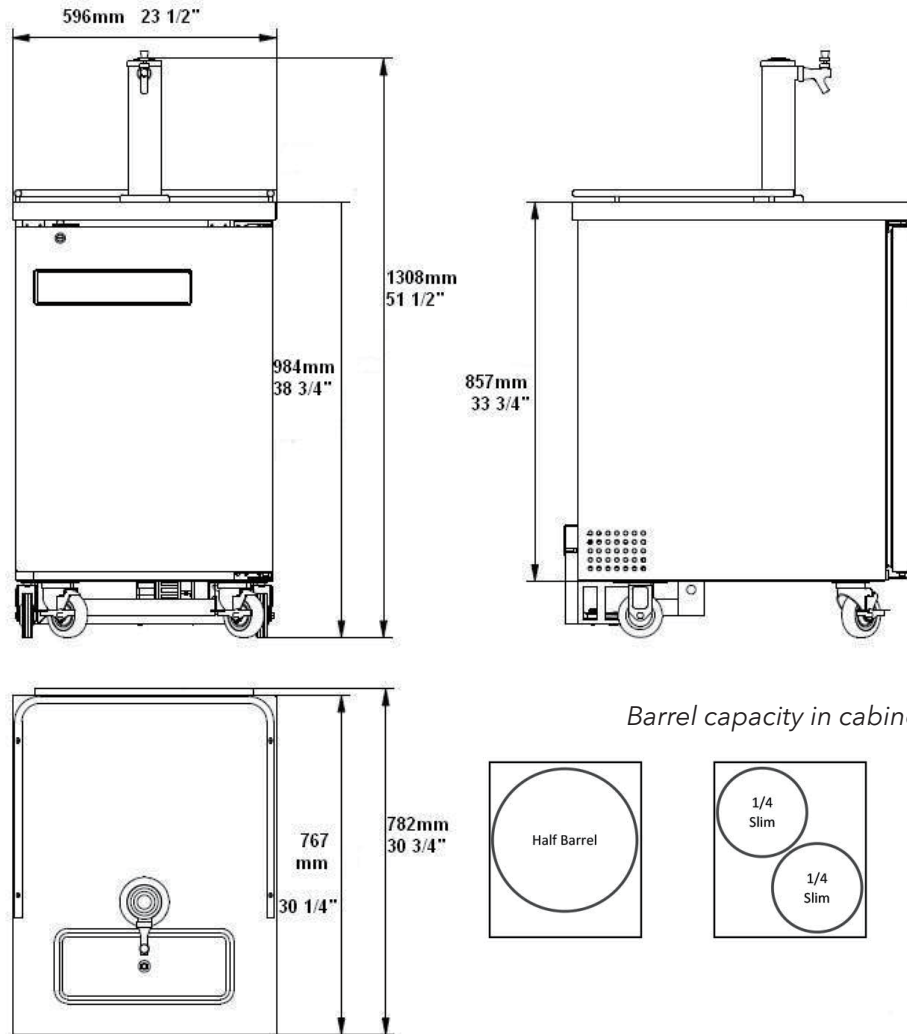

Model	Refrigerant	Doors	Dimension (mm) (inch)			HP	Voltage	Amps	Capacity 1/2 Barrels	Net Weight (KG) (LBS)	Temperature Range
			W	D	H						
CBBDD1-24CC	R290	1	596	782	984	1/6+	115/60/1	1.92	1	84.8	0.5 ~ 5°C
			23.5	30.8	38.7					187	33 ~ 41°F

Equipped with one NEMA 5-15P plug 

*Specifications subject to change without notice.*