

Project Name: _____ AIA#: _____

Model #: _____ Location: _____

SIS#: _____ Item #: _____ Quantity: _____



Chefmate® by Globe Compact Manual Slicer

**Enhanced usability,
cleanability and sanitation
features!**

*Ergonomic handle, lubricated ball bearings,
removable knife sharpener, knife cover and
food chute.*



Model

- C10 – 10" Diameter Knife

Standard Features

- 10" hard chromed special alloy hollow ground knife, longer lasting and easier to sharpen
- 0 to 9/16" slice thickness
- 1/4 HP fan-cooled knife motor with permanently lubricated ball bearings, overload protection and manual reset
- Oversized positive traction grooved belt drive
- Smooth stainless steel ball bearing chute slide for ease of operation
- Stain resistant and easy-to-clean anodized aluminum finish
- Ergonomic dual purpose handle
- Lightweight and compact Italian space-saving design
- Easy to access top mounted, removable all metal knife sharpener — dual action with two stones for a razor sharp cutting edge!
- Food chute, slice deflector and knife cover are removable and easy-to-clean
- Metal bottom enclosure
- Moisture proof, easy-to-clean ON/OFF switch and knife hub
- Sealed splash zones for added sanitation and protection of electronics
- Angled gravity feed chute
- Power indicator light
- Non-slip rubber feet

Warranty

- One-year parts and labor

Optional items

- Slicer cover
- Extended warranty

To select options, see complete list on back

Approved by: _____ Date: _____

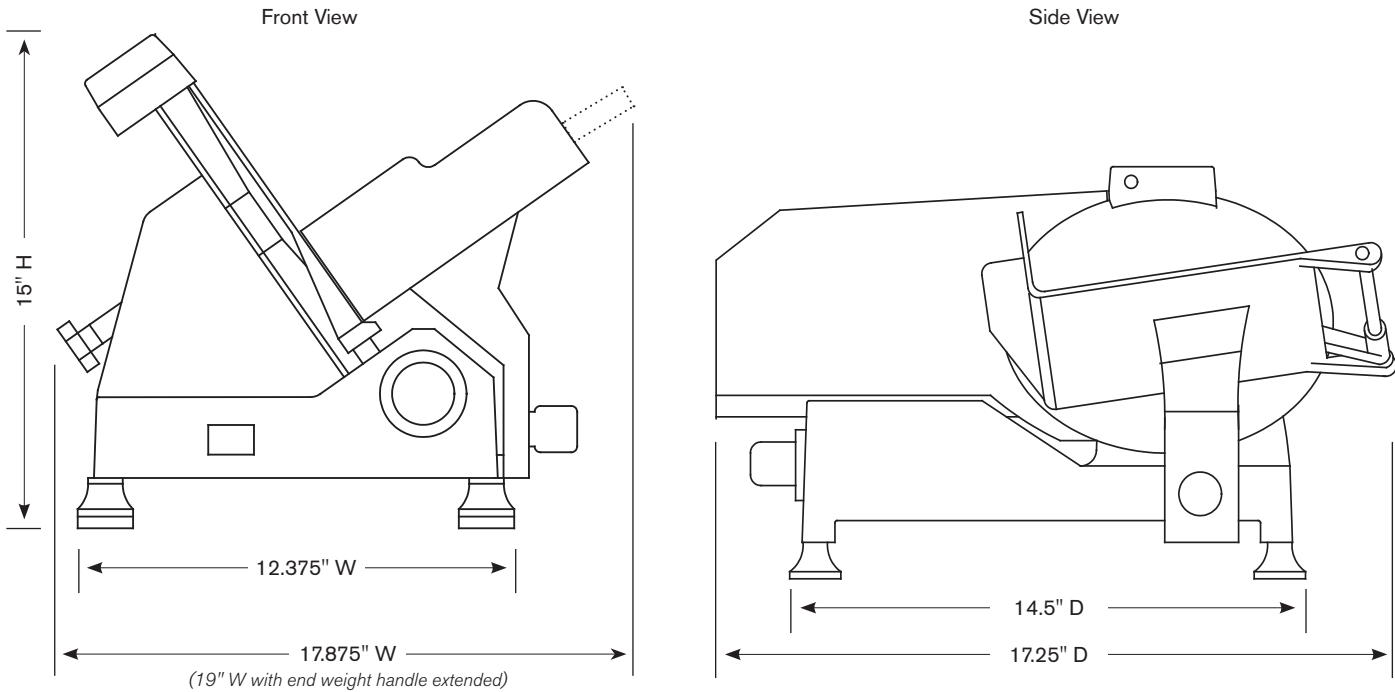

| SPECIFICATIONS | | | | | | | | | | | | |
|----------------|----------------|--------|----------|------|------------|------------------------|--------------------------|------------------|-------------------|--------------------------|-------------------|--------------------|
| Model | Auto or Manual | Motor | Volts | Amps | Drive Type | Slicing Volume per Day | Cheese Slicing | Blade Diameter | Max Slice | Product Cutting Capacity | | |
| | | | | | | | | | | W (Width) | D (Diameter) | H (Height) |
| C10 | Manual | 1/4 HP | 115-60-1 | 2.5 | Belt | < 30 minutes | Not Recommended Time | 10" (22.8 cm) | 9/16" (1.4 cm) | 8.6" (23 cm) | 6.8" (17.4 cm) | 7.25" (18.4 cm) |

Cord & Plug: Attached 5.5 foot flexible 3-wire cord with molded plug fits a grounded receptacle. NEMA 5-15

| DIMENSIONS SHIPPING INFORMATION | | | | |
|--|---|-----------------------|--|-------------------|
| Reinforced carton for shipping. The weight and dimensions of this reinforced carton are included below and may vary from shipment to shipment. Freight class 85. | | | | |
| Model | Overall Dimensions | Net Wt | Shipping Dimensions | Shipping Wt |
| C10 | 19" w x 17.25" d x 15" h (48.3 cm x 43.8 cm x 38 cm) | 33.6 lbs (15.2 kg) | 18" w x 22" d x 17" h (46 cm x 56 cm x 43 cm) | 38 lbs (17 kg) |

Manual slicer with 10" diameter hard chromed, special alloy, hollow ground knife with stain resistant anodized aluminum finish. Unit has 1/4 HP fan cooled motor with overload protection, manual reset, permanently lubricated ball bearings and positive traction grooved drive belt. Slicer has top mounted, removable, dual action knife sharpener with two stones, and removable food chute, slice deflector and knife cover. On/Off switch and electric wiring are moisture proof, with sealed splash zones. Slicer is NSF and ETL listed. One year parts and labor warranty.

OPTIONAL ITEMS:

- SC-SMALL** small slicer cover
 - C-XDSL** Extended warranty, extends factory warranty to 2 years on parts and labor in the continental U.S.
- Available only at time of purchase.*