



Project _____
 AIA # _____ SIS # _____
 Item # _____ Quantity _____ C.S.I. Section 114000

B12-SLC

Gravity Feed Slicer



Model B12-SLC



SPECIFIER STATEMENT

Berkel Model B12-SLC manual gravity feed slicer features Berkel's hollow ground chromium-plated, carbon steel knife and built-in sharpener. The permanent, tapered guard covers the non-slicing portion of the knife, even when the center plate is removed. The 45° table makes product feed easier, creating more consistent and uniform slices with less waste. The ½ HP motor, 12" knife and large product table are ideal for handling oversize meats, cheeses and a variety of other products. The B12-SLC is easy to clean and disassembles quickly without tools. The compact space-saving design is ideal for limited kitchen counter space.

Complies with NSF/ANSI Standard #8.

PERFORMANCE FEATURES

- 1-speed, ½ HP, totally enclosed and permanently lubricated knife motor
- Precise slice adjustment to a thickness of 1/16" (14 mm)
- Carriage handles food up to 10¾" (273 mm) wide, by 7¾" (194 mm) high or 7¾" (187 mm) diameter
- Furnished in 115/60/1, 4.0 amp, AC, ETL listed

EASY TO OPERATE FEATURES

- 45° product table with removable meat pusher
- Top-mounted, two stone knife sharpener produces a consistently sharp knife edge
- Attached 6-foot, flexible, 3-wire cord and plug for grounded receptacle (5-15P)
- No Volt Release

EASY TO CLEAN FEATURES

- Removable carriage arm
- Permanent, tapered knife ring guard covers non-slicing portion of knife even when the center plate is removed; ring guard design provides more room behind the knife for easy cleaning
- Finish is stainless steel and sanitary anodized aluminum; unit disassembles quickly without tools for easy cleaning
- Nominal 12" (300 mm) diameter; hollow ground, hardened and polished forged chromium-plated carbon steel knife
- Positive, moisture protected, on/off switch with power light indicator

B12-SLC – Gravity Feed Slicer

Approved by _____ Date _____ Approved by _____ Date _____



B12-SLC Gravity Feed Slicer

SPECIFICATIONS

Motor: 1-speed, ½ HP, totally enclosed, permanently lubricated ball bearings, thermally protected.

Electrical: Furnished in 115/60/1, 4.0 amps, AC, ETL listed.

Finish/Construction: All food contact areas are stainless steel or anodized aluminum including the pusher, gauge plate, product table, center plate, knife ring guard and one-piece base. Slicer disassembles quickly without tools for easy cleaning.

Knife: Nominal 12" (300 mm) diameter, hollow ground, hardened and polished forged chromium-plated carbon steel, rotates at 380 rpm.

Cutting Capacity: Carriage handles food up to 10¾" (273 mm) wide by 7⅝" (194 mm) high or 7⅜" (187 mm) diameter.

Slice Thickness: Precision system provides infinite slice adjustment and consistent cuts of hard or soft foods from tissue thin to ⅝" (14 mm).

Full Gravity Feed: Full 45° angle feed requires less mechanical pressure. Equipped with removable anodized aluminum pusher to hold product and minimize waste.

Knife Sharpener: Top mounted, two stone system for a lasting, razor-sharp edge.

Knife Ring Guard: Permanent, tapered guard covers non-slicing portion of knife edge even when the center plate is removed. The ring guard is designed to provide added room behind the knife for easy cleaning.

On/Off Switch: Highly reliable, moisture resistant, on/off switch with power light indicator.

Cord and Plug: Attached 6-foot, flexible, 3-wire cord and plug for grounded receptacle (5-15P).

Warranty: All parts, service and travel coverage for one year, excluding wear items.

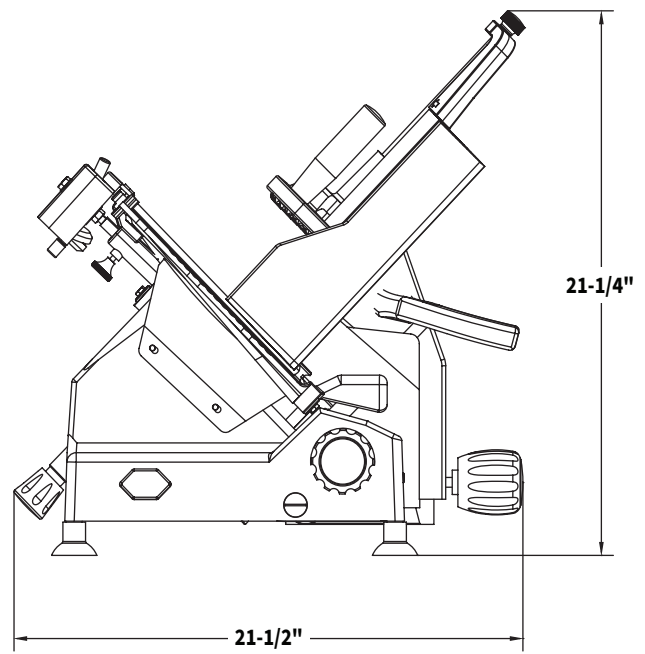
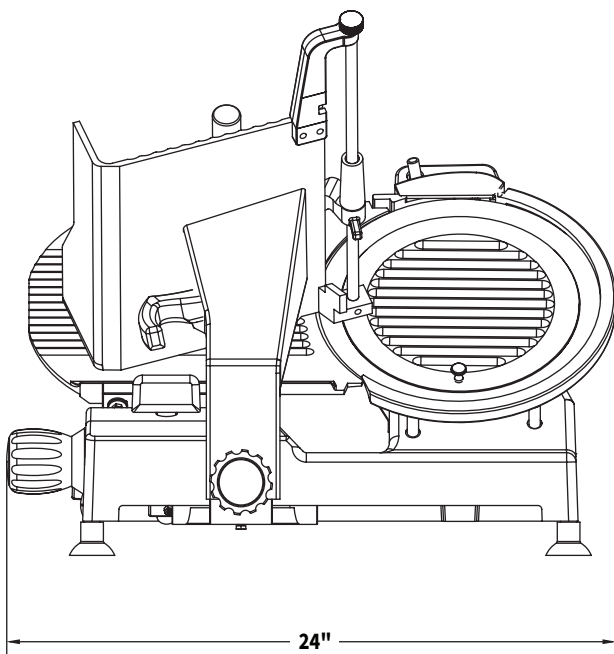

MODEL NUMBER	CUTTING CAPACITY	SLICE THICKNESS	KNIFE DIAMETER	PRODUCT DIMENSIONS		
				WIDTH	DEPTH	HEIGHT
B12-SLC	10¾" (273 mm) wide 7⅝" (194 mm) high 7⅜" (187 mm) diameter	to ⅝" (14 mm)	12" (300 mm)	21½" (546 mm)	24" (610 mm)	21¼" (540 mm)

MODEL NUMBER	MOTOR	ELECTRICAL	WEIGHT	BOX DIMENSIONS		
				WIDTH	DEPTH	HEIGHT
B12-SLC	1-speed ½ HP	115/60/1 4.0 amps	Net 60 lbs. (28 kg) Ship 74 lbs. (34 kg)	23½" (597 mm)	32½" (826 mm)	27¾" (705 mm)

As continued product improvement is a policy of Berkel, specifications are subject to change without notice.