



# Water Filters

SSM Plus and Aqua Patrol Plus® Water Filtration Systems

## Features

### SSM Plus

- Extends the life of your Scotsman machine and provides cleaner, more consistent ice.
- Now with AquaArmor with AgION®, a silver-based anti-microbial compound that reduces the growth of bacteria, microorganisms, algae, mold and slime on ice machine surfaces, preventing premature clogging.
- Ultrafine half-micron filtration, combined with food-grade polyphosphate, assures that chlorine, off-tastes, odors and particles stay out of your ice.
- Filtration can reduce unscheduled water-related maintenance calls by as much as 40%.
- Easy to install and maintain.

### AquaPatrol Plus®

- Leaves chlorine in water to keep machine cleaner longer.
- Polyphosphate feed to inhibit scale build up.
- Easy to install and maintain.
- Tighter pore size now eliminates more undesirable compounds.
- New smaller footprint gives operations more flexibility.



SSM3-P



AP3-P

## NSF International Standards

### Standard No. 42: Aesthetic Effects

#### Chemical Unit

- Chlorine reduction, class 1
- Taste and odor reduction

#### Mechanical Filtration Unit

- Particle reduction, class 1
- 99.9% reduction of particles
- 1/2 micron and larger sizes

### Standard No. 53: Health Effects

#### Mechanical Filtration Unit

- Turbidity reduction
- Cyst reduction
- Asbestos reduction

The SSM and AquaPatrol Plus filter and replacement cartridge have been tested and listed by NSF only for the functions listed above. Check for compliance with state and local law and regulations. Do not use where the water is micro-biologically unsafe, or with water of unknown quality without adequate disinfection before or after the unit. Can be used on water that may contain filterable cysts.



## Certification



## Warranty

- 5 years on manifold parts only
- Warranty valid in North, South & Central America for commercial installations.
- Contact factory for warranty in other regions.
- Residential Applications: 1 year parts and labor

# Scotsman®

• 101 Corporate Woods Parkway, Vernon Hills, IL 60061 •  
• 1-800-SCOTSMAN • Fax: 847-913-9844 • www.scotsman-ice.com • customer.relations@scotsman-ice.com •

Water Filters

# Water Filters

## SSM Plus and Aqua Patrol Plus® Water Filtration Systems

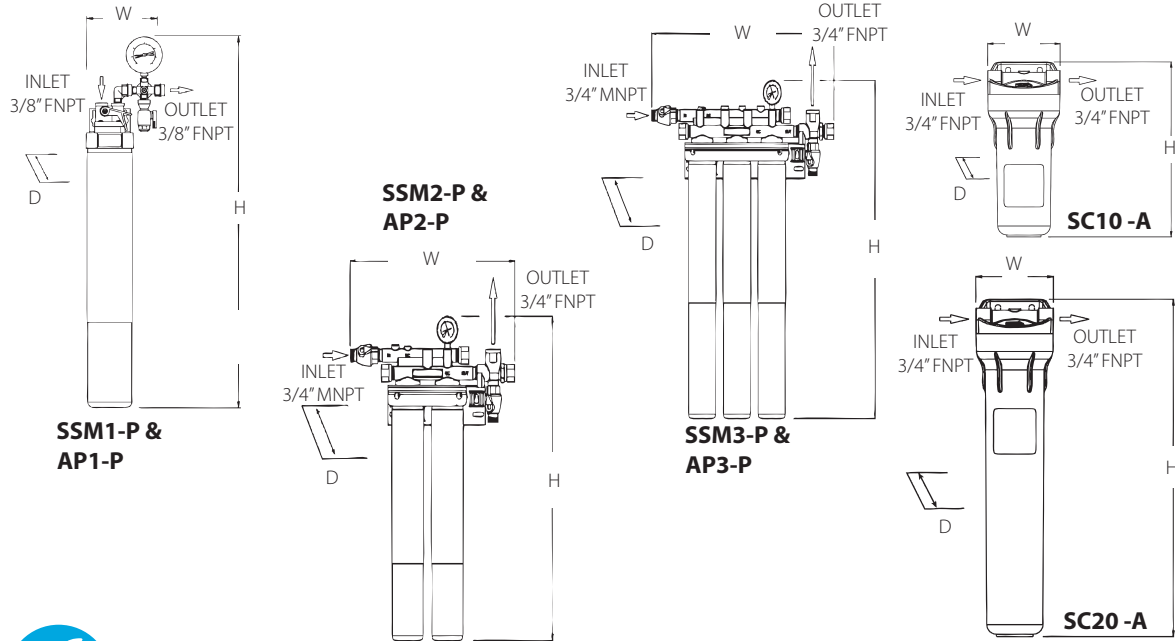

### Specifications

Model Number	Dimensions			Description	Maximum Flow (gallons/minute)	
	W	D	H			
SSM Plus	SSM1-P	5.6	4.75	30.5	Single System for Cubers up to 650 lb (295 kg) and flakers, nuggets and nugget dispensers up to 1,200 lb (544 kg).	1.67
	SSM2-P	16.6	5.5	29.26	Double System for Cubers up to 650 lb (295 kg) and flakers, nuggets and nugget dispensers up to 1,200 lb (544 kg).	3.34
	SSM3-P	21	5.5	29.26	Triple System for Cubers over 1,300 lb (544 kg)	5.01
AquaPatrol Plus®	AP1-P	5.6	4.75	21.5	Single System for Cubers up to 650 lb (295 kg) and flakers, nuggets and nugget dispensers up to 1,200 lb (544 kg).	2.1
	AP2-P	16.6	5.5	19.26	Double System for Cubers up to 650 lb (295 kg) and flakers, nuggets and nugget dispensers up to 1,200 lb (544 kg).	4.2
	AP3-P	21	5.5	19.26	Triple System for Cubers over 1,300 lb (544 kg)	6.3
Coarse Pre-Filters	SC10-A	5.16	5.5	12.44	Single System for Cubers up to 650 lb (295 kg) and flakers, nuggets and nugget dispensers up to 1,200 lb (544 kg).	5
	SC20-A	5.16	5.5	22.44	Single System for Cubers up to 650 lb (295 kg) and flakers, nuggets and nugget dispensers up to 1,200 lb (544 kg).	10



### Shipping

Model Number	Dimensions	Weight (lb/kg)
SSM1-P:	21" x 10" x 6"	7/3
SSM2-P:	26" x 16" x 13"	11/5
SSM3-P:	26" x 16" x 13"	16/7
AP1-P:	10" x 21" x 6"	7/3
AP2-P:	16" x 26" x 13"	11/5
AP3-P:	16" x 26" x 13"	16/7
SC10-A:	6" x 6" x 17"	5/2
SC20-A:	6" x 6" x 26"	11/5



### Accessories

Model Number	Description
SC10RC40	SC10 Replacement Filter (package of 40)
SC20RC20	SC20 Replacement Filter (package of 20)
SSMRC1	Replacement Cartridge for SSM Plus (package of 1)
SSMRC6	Replacement Cartridge for SSM Plus (package of 6)
APRC6-P	Replacement Cartridge for AquaPatrol Plus® (package of 6)
APRC1-P	Replacement Cartridge for AquaPatrol Plus® (package of 1)

Scotsman recommends all ice machines have water filtration.



### Operating Requirements

	Minimum	Maximum
Air Temperatures	50°F (10°C)	100°F (38°C)
Water Temperatures	40°F (4.4°C)	100°F (38°C)
Water Pressures	20 PSIG (1.4 bar)	80 PSIG (5.5 bar)

Specifications and design are subject to change without notice.

Water Filters