



Project _____
 AIA # _____ SIS # _____
 Item # _____ Quantity _____ C.S.I. Section 114000



6115 - PEELER

6115
 Peeler



MODEL

- 6115** 15 lb. capacity peeler

STANDARD FEATURES

- + 1/3 HP motor with manual reset thermal overload protection
- + Satin stainless steel finish housing
- + 5 minute timer
- + Removable NSF Lexan liner
- + Removable 14 3/4" silicon carbon abrasive disc
- + Stainless steel drive shaft
- + Removable cam-type pressure lock-in hopper door
- + Heavy duty brushed aluminum lock-in hopper cover
- + Resilient Buna S Rubber trim molding
- + Rear mounted water inlet with 5' fill hose
- + Cord and plug

ACCESSORIES

- Cabinet base and peel trap
- Portable stand
- Peel trap basket
- 3" leg extension
- Equipment stand

SPECIFIER STATEMENT

Specified unit is a UL and NSF approved peeler with 15 pound capacity and satin stainless steel finish. Unit features a 5 minute timer, removable NSF Lexan liner, removable silicon carbon abrasive disc and 1/3 HP motor with manual reset thermal overload protection.

Approved by _____ Date _____ Approved by _____ Date _____



SOLUTIONS / BENEFITS

PERFORMANCE

Stainless Steel Drive Shaft

- + Advanced design for long life and performance

Satin Stainless Steel Finish Housing

- + Cylindrical construction heliarc-welded stainless steel

Silicon Carbide Abrasive Disc

- + 14³/₄" diameter lightweight fiberglass reinforced plastic disc with silicon abrasive permanently bonded for high volume usage

EASE OF USE

5 Minute Timer

- + Adjusts for any increments from 30 seconds to 5 minutes, with 15 second markers on timer dial

Heavy Duty Brushed Aluminum Lock-in Hopper Cover

- + Allows product to be monitored
- + Aluminum, heavy-duty, easily removable for cleaning

SANITATION & CLEANING

Rear-Mounted Water Inlet with 5' Fill Hose

- + Water from inlet strikes curved surface of hopper cover, promoting interior self-cleaning and preventing undesirable splash
- + Sufficient height to meet plumbing codes

Removable NSF Lexan Liner

- + Quickly removed for cleaning

Silicon Carbide Abrasive Disc

- + Quickly removed for cleaning

OPERATOR ASSURANCE

Bowl Cover Interlock

- + Peeler will not operate unless cover is in place

Thermal Overload Protection with Manual Reset

- + Protects peeler from overheating; located on the outside of the hopper opposite the discharge chute
- + If, during operation, the motor should overheat and trip this switch, turn the timer off and allow the motor to cool for several minutes

SPECIFICATIONS

Electrical: 115/60/1; 7.2 amps, 230/60/1; 3.6 amps, 230/50/1; 3.4 amps – UL listed.

Motor: ½ HP, permanently lubricated bearings, capacitor-start, induction run type with manual reset thermal overload protection.

Cord and Plug: 5½ feet, 3 wire, flexible cord and plug for grounding. Cord and plug not supplied on export models.

Double V-Belt Drive: Speed reduction between motor and disc drive is obtained directly through dual V-belts.



Accessories: Portable stand and peel trap basket. Portable stand gives mobility and eliminates lifting peeler. Peel trap basket is suspended from the discharge hose, inside the sink, to strain the peelings before reaching the drain.

Warranty: Unit has full one-year warranty on parts, labor and mileage against manufacturer's defects. Service contracts are available.

Weight: Shipping – 74 lbs.; Net – 60 lbs.

Plugs and Receptacles:

Dependent on local power codes

	Machine Voltages			
	6115	115/60/1	230/50/1	230/60/1
Service Current Requirement if Plug Connected	120/60/1	230/50/1	230/60/1	
	15 Amp.	20 Amp.	15 Amp.	
Terminal Designation of Plug	2 Pole 3 Wire Grounding		2 Pole 3 Wire Grounding	
NEMA Plug Configuration	5-15P		6-15P	
Plug Configuration				
Molded Plug on Cord	Yes		Yes	
Plug - Straight/Angle	Straight		Straight	
NEMA Receptacle or Connector Configuration	5-15R		6-15R	
Power Cord Included	Yes	No	Yes	

DETAILS AND DIMENSIONS – MODEL 6115 PEELER

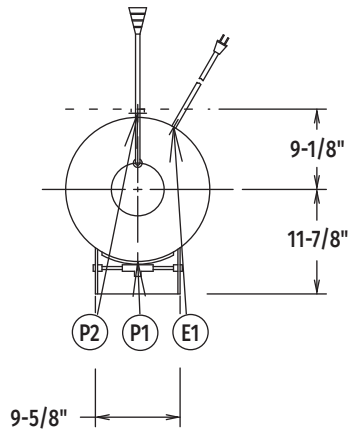

LEGEND

Electrical Connections	
E1	Cord & plug (approximately 5-1/2 ft. from side of the machine).
Plumbing Connections	
P1	Drain connection - 2" standard male pipe thread.
P2	Fill connection - standard 1/2" female pipe thread.

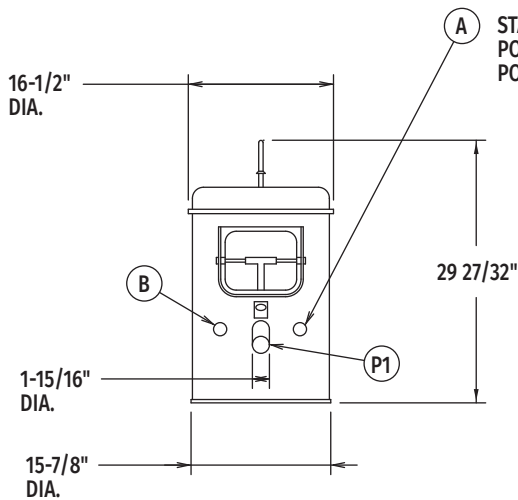

WARNING: Electrical and grounding connections must comply with the applicable portions of the National Electrical Code and/or other local electrical codes.

Plumbing connections must comply with applicable sanitary, safety and plumbing codes in force.

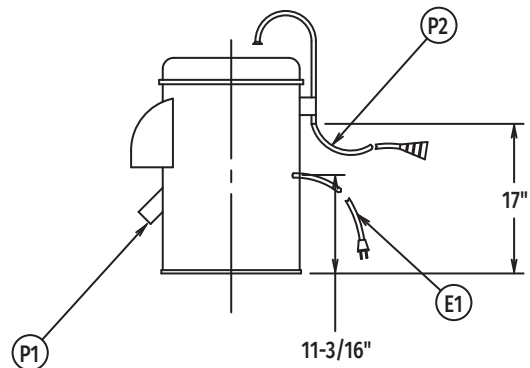
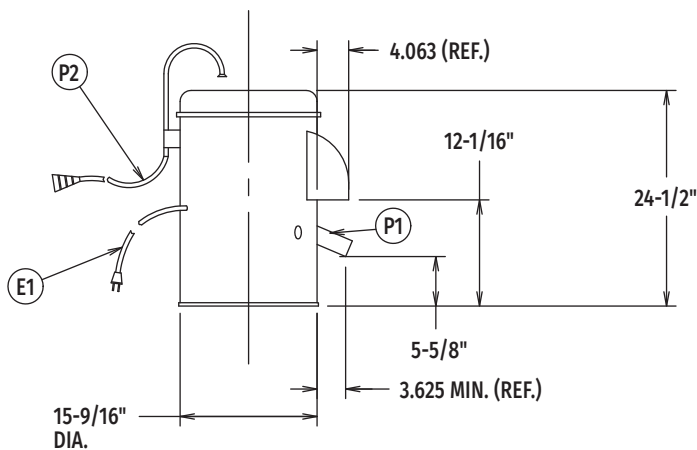

Model/ Electrical Code	Electrical Specification	Amps
6115/A	115/60/1	7.2
6115/C	230/60/1	3.6

DETAILS AND DIMENSIONS – CABINET BASE AND PEEL TRAP

LEGEND

Electrical Connections	
E1	Cord & plug (approximately 5-1/2 ft. from side of the machine).
Plumbing Connections	
P1	Drain connection - 2" standard male pipe thread.
P2	Fill connection - standard 1/2" female pipe thread.

WARNING: Electrical and grounding connections must comply with the applicable portions of the National Electrical Code and/or other local electrical codes.

Plumbing connections must comply with applicable sanitary, safety and plumbing codes in force.

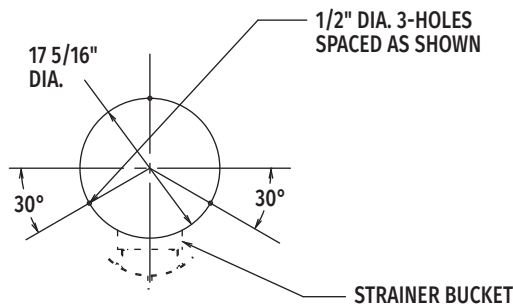

PLAN VIEW OF PEEL TRAP SHOWING HOLES IN LEGS FOR USE IN FASTENING TO FLOOR WHEN REQUIRED.

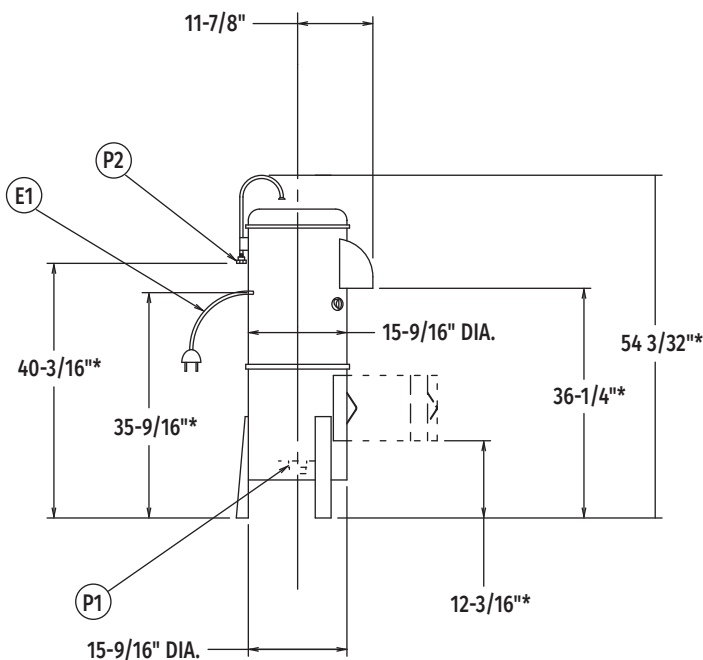

Peel Trap Weight: Shipping – 43 lbs.; Net – 38 lbs.

*These dimensions may increase 2½" depending on leg adjustment.

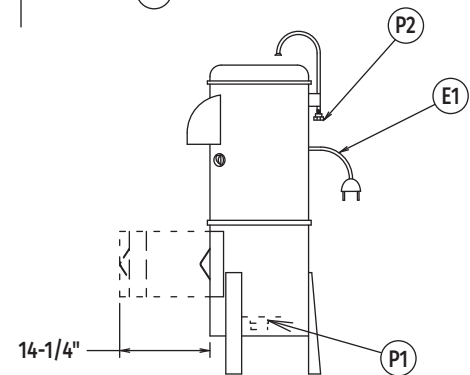
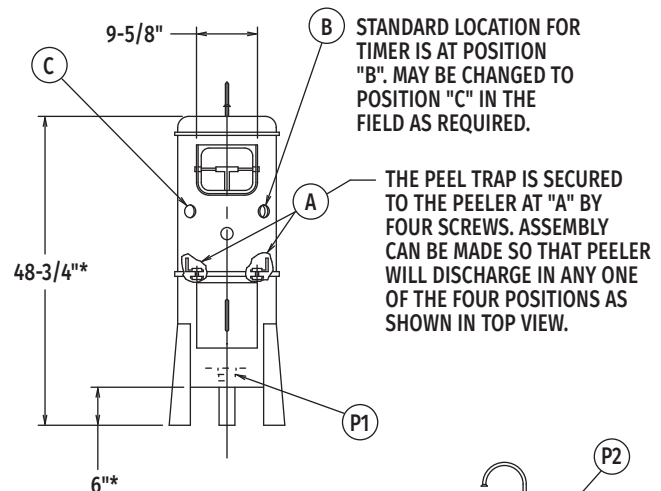
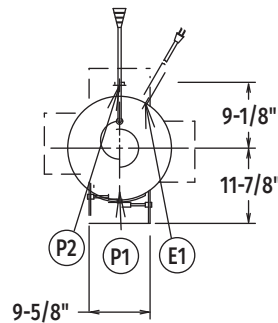

Model/ Electrical Code	Electrical Specification	Amps
6115/A	115/60/1	7.2
6115/C	230/60/1	3.6