



SERVING THE FOOD INDUSTRY SINCE 1951

2-HP FLOOR BAND SAW

Item: 10271 Model: BS-VE-2489-E



**CUT SLABS OF MEAT QUICKLY,
EASILY, AND PRECISELY**

Fabricated in steel with electrostatic oven paint, complete with an aluminum head. Its stainless steel table has a four-wheel base that slides on rails. Equipped with adjustable legs. Easy to disassemble for quick cleaning and maintenance.



WARRANTY
PARTS AND LABOR



Authorized Dealer

FOOD EQUIPMENT

2-HP FLOOR BAND SAW BS-VE-2489-E / 10271

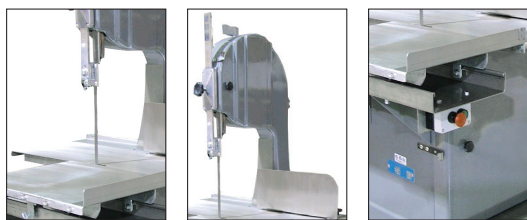

TECHNICAL SPECIFICATION

ITEM NUMBER	10271
MODEL	BS-VE-2489-E
BLADE LENGTH	98" / 2489 mm
CUTTING CAPACITY (H*W)	12" x 10.5" / 305 x 267 mm
POWER	2 HP / 1.5 kW
ELECTRICAL	220 V / 60 Hz / 1 Ph
WEIGHT	346 lbs. / 157 kg.
PACKAGING WEIGHT	400 lbs. / 181 kg.
PACKAGING DIMENSIONS	36" x 40" x 72" 914 x 1016 x 1829 mm

TECHNICAL DRAWING AND DIMENSIONS

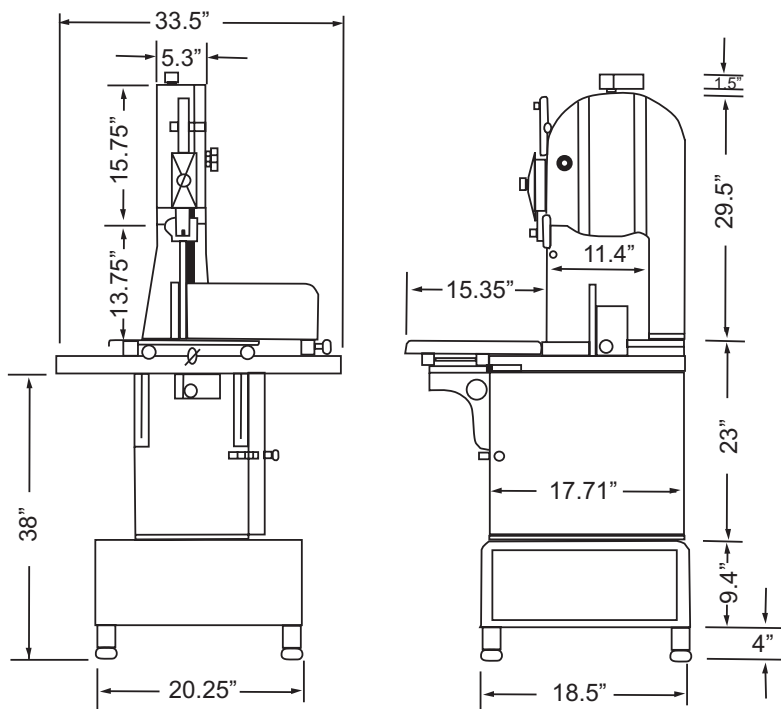

Features

- Stainless steel finish with electrostatic oven paint
- Perfect for large restaurants, butcher shops, and supermarkets
- Easy accessibility for operation, disassembly, and cleaning



WARRANTY
PARTS AND LABOR



OMCAN INC.

Telephone: 1-800-465-0234

Fax: (905) 607-0234

Email: sales@omcan.com

Website: www.omcan.com



Follow us to keep up to date with the latest news and offers



2015.E.O.E